

Product Model

POW-SunSmart 16KP



# POWMr

All-in-One Solar Charge Inverter

User Manual

---

## Important Safety Instructions

---

Please save these instructions for future use!

- ⚠ Read all of the instructions and cautions in the manual before beginning the installation!
- Installation and wiring must comply with the Local and National Electric Codes (NEC) and must be done by a certified technician.
- Do NOT disassemble or attempt to repair the inverter. There are no serviceable parts for this inverter.
- DO NOT parallel this device with other AC input sources to avoid damage.
- DO NOT attempt to touch the unit while it is operating as temperatures will be very hot. In addition, do not open the terminal cover while the unit is in operation.
- Make sure all connections going into and from the inverter are tight. There may be sparks when making connections, therefore, make sure there are not flammable materials or gases near installation.
- Installing breakers or fuses outside of the unit is recommended.
- After installation, check that all line connections are tight and secured.
- Do NOT let the positive (+) and negative (-) terminals of the battery touch each other. Use Lithium batteries or deep cycle Sealed Lead Acid, Flooded, Gel, AGM batteries.
- Explosive battery gases may be present while charging. Be certain there is enough ventilation to release the gases.
- Be careful when working with large lead acid batteries. Wear eye protection and have fresh water available in case there is contact with the battery acid.
- Over-charging and excessive gas precipitation may damage the battery plates and activate material shedding on them. Too high of an equalizing charge or too long of one may cause damage. Please carefully review the specific requirements of the battery used in the system.

## Table of Contents

<b>Important Safety Instructions .....</b>	<b>1</b>
<b>1 About This Manual.....</b>	<b>2</b>
1.1 How to Use This Manual .....	2
1.2 Symbols in This Manual.....	2
1.3 Disclaimer and Limitation of Liability.....	2
<b>2 Production Instructions.....</b>	<b>3</b>
2.1 Instructions.....	3
2.2 Features.....	3
2.3 System Connection Diagram .....	5
2.4 Product Overview .....	6
2.5 Product Size .....	7
<b>3 Installation.....</b>	<b>8</b>
3.1 Parts List .....	8
3.2 Select the Mount location .....	10
3.3 Mount the Inverter .....	11
3.4 Removing the Terminal Protection Cover.....	13
<b>4 Connection Instructions .....</b>	<b>14</b>
4.1 Split-Phase Mode .....	14
4.2 Cable & Circuit Breaker Requirement.....	16
4.3 Grid & Load & Generator Connection .....	18
4.4 Battery Connection .....	19
4.5 PV Connection .....	20
4.6 Dry Contact Connection .....	22
4.7 Grounding Connection .....	22
4.8 Inverter Start.....	23
<b>5 Operation.....</b>	<b>24</b>
5.1 Operation and Display Panel .....	24
5.2 View Real-time Data .....	27
5.3 Setting .....	28

5.4 AC Output Mode .....	40
5.5 Battery Charging Mode.....	42
5.6 Time-slot Charging/Discharging Function.....	43
5.7 Battery Parameters.....	44
<b>6 Communication .....</b>	<b>46</b>
6.1 Product Overview .....	46
6.2 Parallel Function (For parallel operation only) .....	47
6.3 CAN Function.....	48
6.4 RS485/CAN Communication Function .....	49
6.5 DRM (Reserved, Only Australia) .....	50
6.6 External CT Connection .....	51
6.7 Meter Communication (Optional) .....	53
6.8 WiFi Communication Function.....	54
6.9 USB-1 Communication Function.....	55
6.10 Dry Contact Port.....	56
<b>7 Fault Codes and Response Measures.....</b>	<b>57</b>
7.1 Fault Codes.....	57
7.2 Trouble Shooting .....	61
<b>8 Protection Function and Maintenance .....</b>	<b>63</b>
8.1 Protection Function.....	63
8.2 Maintenance.....	65
8.3 Storage .....	66
<b>9 Parameter Table .....</b>	<b>67</b>
<b>10 Appendix I: Parallel Connection .....</b>	<b>70</b>
10.1 Parallel Operation .....	70
10.2 Precautions for Connecting Parallel Connection Cables .....	70
10.3 Wiring diagram for split-phase parallel connection (phase difference between L1 and L2: 180°).....	72
10.4 Wiring diagram for three-phase parallel connection .....	74

## 1 About This Manual

### 1.1 How to Use This Manual

This manual contains important information, guidelines, operation and maintenance for the following products: POW-SunSmart 16KP.

Read the manual and other related documents before performing any operation on the inverter. Documents must be stored carefully and be available at all times.

### 1.2 Symbols in This Manual

Symbol	Description
<b>DANGER</b>	DANGER indicates a hazardous situations which if not avoided will result in death or serious injury.
<b>WARNING</b>	WARNING indicates a hazardous situations which if not avoided could result in death or serious injury.
<b>CAUTION</b>	CAUTION indicates a hazardous situations which if not avoided could result in minor or moderate injury.
<b>NOTICE</b>	NOTICE provide some tips on operation of products.

### 1.3 Disclaimer and Limitation of Liability

**Our company will not be held responsible for damage due to the following reasons:**

- Damage caused by improper use or use in the wrong location.
- The open circuit voltage of the PV module exceeds the maximum allowable voltage.
- The operating temperature exceeds the limited operating temperature range.
- Unauthorized personnel dismantle, and repair the inverter.
- Force majeure: damage during transportation or handling of the inverter.

## 2 Production Instructions

### 2.1 Instructions

The POW-SunSmart series is a new type of solar energy storage inverter control inverter integrating solar energy storage & utility charging and energy storage, AC sine wave output. It adopts DSP control and features high response speed, reliability, and industrial standard through an advanced control algorithm. It applies to industrial scenarios.

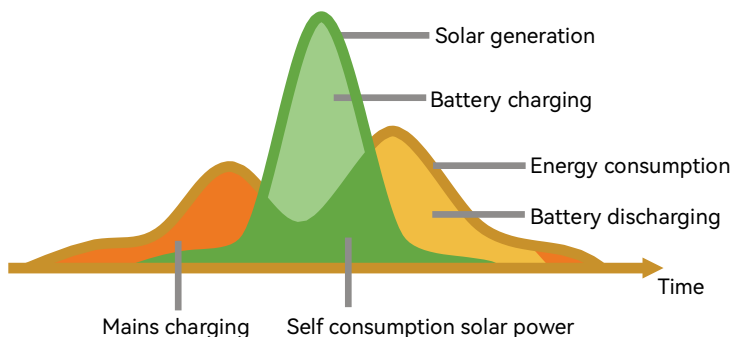

### 2.2 Features

- Support the connection of various types of energy storage batteries such as lead-acid battery and lithium-ion battery.
- Features Dual activation function when lithium-ion batteries are in hibernation; activation of lithium-ion batteries can be triggered by either mains power or photovoltaic power input.
- Support split-phase pure sine wave output.
- Support adjusting the voltage of each phase within the range of 100 VAC, 105 VAC, 110 VAC, 115 VAC, 120VAC, 127VAC.
- Supports two-way photovoltaic input, with the function of simultaneously tracking the maximum power charging or load-carrying capacity of two MPPTs.
- Dual MPPT with 99% efficiency and maximum 36A current in a single circuit, perfectly adapted to high power modules.
- Provide two charging modes: only PV and grid + PV.

- Have the timed charge and discharge function, that is, users can set the charge and discharge time according to the time-of-use price to save electricity costs.
- Have the energy-saving mode, reducing no-load energy losses.
- With two output modes of utility bypass and inverter output, with uninterrupted power supply function.
- LCD large screen dynamic flow diagram design, easy to understand the system data and operation status.
- 360° protection with complete short circuit protection, over current protection, over/under voltage protection, overload protection, backfill protection, etc.
- Support CAN, USB, and RS485 communication.
- Support 130% unbalanced load.

## 2.3 System Connection Diagram

The diagram below shows the system application scenario of this product. A complete system consists of the following components:

1. **PV module:** Converts light energy into DC energy, which can be used to charge the battery via an inverter or directly inverted into AC power to supply the load.
2. **Grid or generator:** Connected to the AC input, it can supply the load and charge the battery at the same time. The system can also operate generally without the mains or generator when the battery and the PV module power the load.
3. **Battery:** The role of the battery is to ensure the regular power supply of the system load when the solar energy is insufficient and there is no mains power.
4. **Home load:** It can connect various household and office loads, including refrigerators, lighting fixtures, TVs, fans, air conditioners, and other AC loads.
5. **Inverter:** The energy conversion device of the whole system.

**Note: The actual application scenario determines the specific system wiring method.**

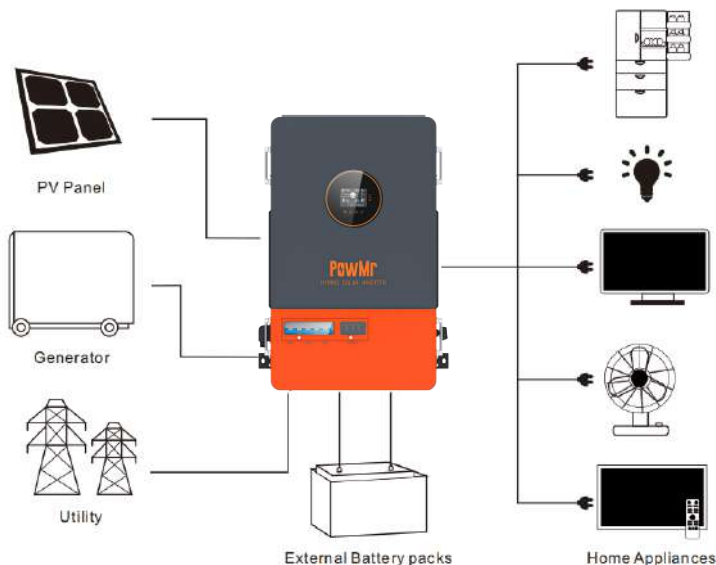

## 2.4 Product Overview

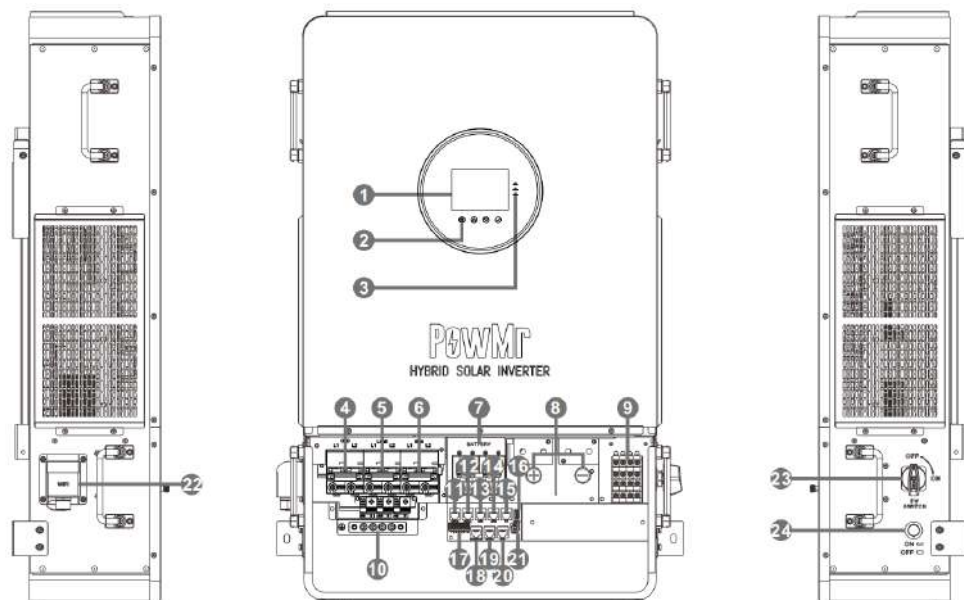

1	LCD Screen	2	Operation Buttons	3	LED Indicator Light
4	Grid Input (L1+L2+N)	5	Load Output (L1+L2+N)	6	Generator Input (L1+L2+N)
7	Battery Circuit Breaker	8	Battery Terminals (Positive + Negative)	9	PV Input
10	Grounding Screw	11	Parallel Port (PAR-B)	12	Parallel Port (PAR-A)
13	CAN Port	14	DRM Port	15	CT Port
16	USB-2 Port	17	Dry Contact Port	18	RS485/CAN Port
19	Meter Port	20	WIFI Port 1	21	USB-1 Port
22	WIFI Port 2	23	PV Switch	24	Power ON/OFF Switch

## 2.5 Product Size

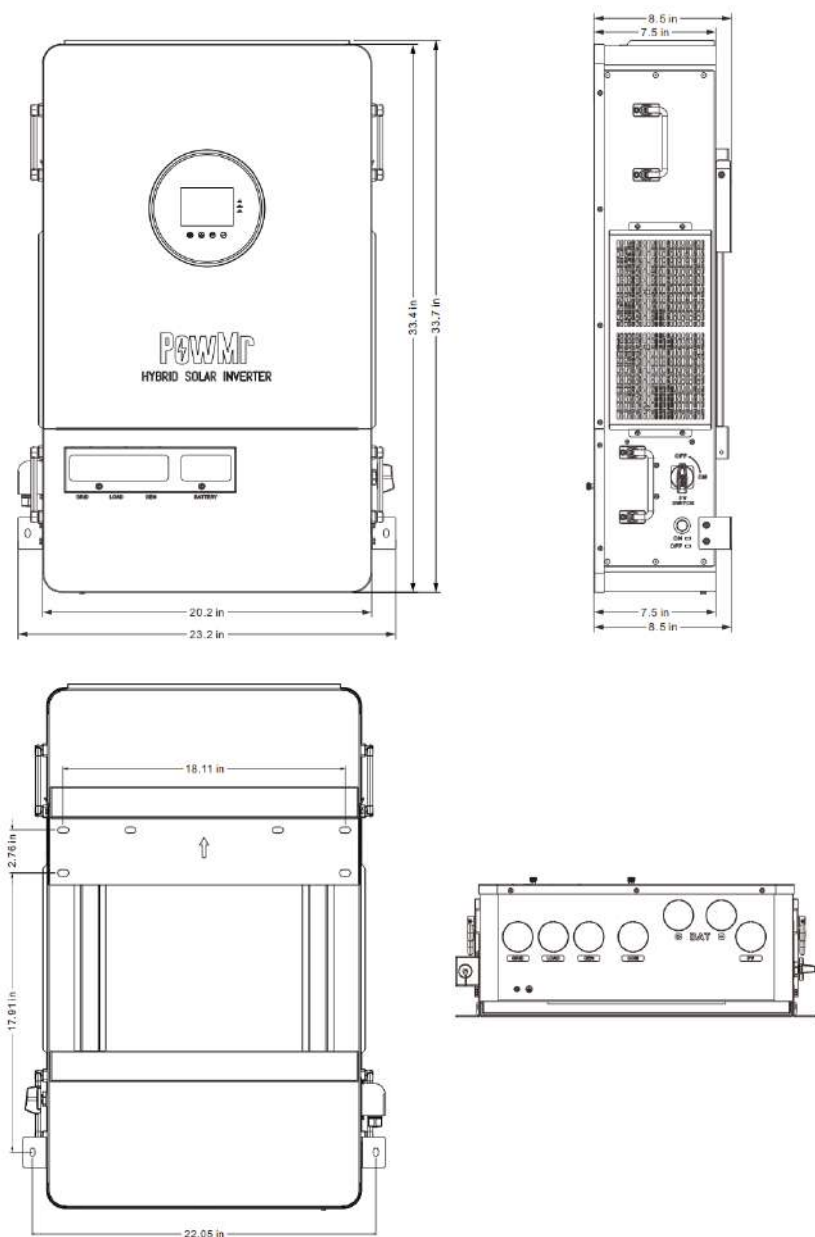









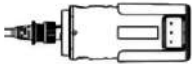

## 3 Installation

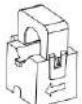
### 3.1 Parts List

Please check the equipment before installation. Make sure that there is no damage to the packaging. You should have received the following items in the package:

NO.	Image	Item	Quantity
1		Inverter	1pcs
2		Wall mount bracket	1pcs
3		Crimp Terminal SC95-8	4pcs
4		M8 flat washer	4pcs
5		Hexagon socket cross recessed screw M8*12mm / M5*10mm	5pcs/ 4pcs
6		Expansion Bolt M8*60mm	4pcs
7		M8 Socket screwdriver	1pcs
8		Round-head self-tapping screws FA6x35 + white rubber plugs	1bag

9		WiFi module	1pcs
10		Parallel cable	1pcs
11		Black screw M4*8mm	4pcs
12		Hex Key_L-Type_5mm	1pcs
13		Ferrule terminal	8pcs
14		CT (Optional)	1pcs
15		Meter (Optional)	1pcs
16		Quality certificate	1pcs
17		Outgoing inspection report	1pcs
18		User manual	1pcs
19		Warranty Card	1pcs

### 3.2 Select the Mount location

The product is designed for indoor use only (IP20 rated). Consider the following factors when selecting the installation location:

- Choose the solid wall to install the inverter.
- Mount the inverter at eye level.
- Adequate heat dissipation space must be provided for the inverter.
- The ambient temperature should be between  $-10^{\circ}\text{C} \sim 55^{\circ}\text{C}$  ( $14^{\circ}\text{F} \sim 131^{\circ}\text{F}$ ) to ensure optimal operation.

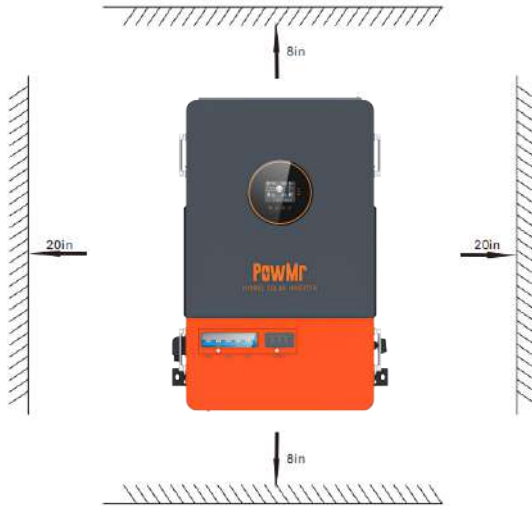

#### DANGER

- Do not install the inverter where highly flammable materials are nearby.
- Do not install the inverter in potential explosive areas.
- Do not install the inverter with lead-acid batteries in a confined space.

#### CAUTION

- Do not install the inverter in direct sunlight.
- Do not install or use the inverter in a humid environment.

### 3.3 Mount the Inverter

Step 1. Use the wall-mounting bracket as a template to determine the drilling positions. Ensure the holes are level, mark them with a marker, and use a rotary hammer to drill into the wall. Keep the drill perpendicular to the wall to avoid shaking and prevent surface damage. If there is significant deviation in hole positioning, remeasure and reposition.

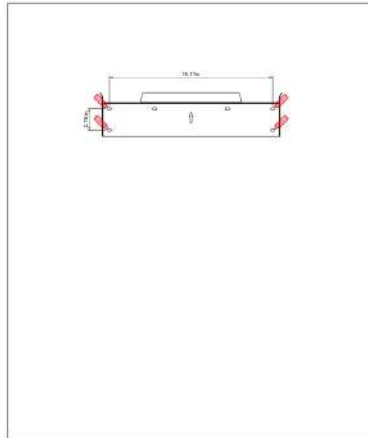

Step 2. Select a solid wall with a thickness of  $\geq 3.15$  in., and drill four holes according to the marked positions (hole diameter:  $\phi 8$ , depth: 1.77~1.97 in). Insert M8 expansion bolts into the holes and tighten the nuts securely.

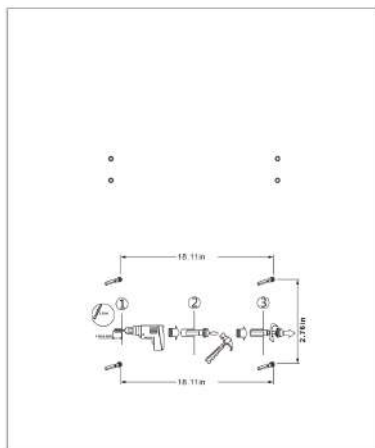

Step 3. Align the wall-mounting bracket with the drilled holes, and fasten it firmly to the wall by tightening the expansion bolts and nuts.

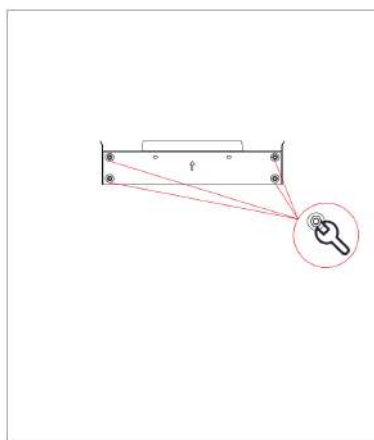

Step 4. ① Install the inverter. Slowly hang the inverter on the frame via the matching hooks, then tighten the screws on both sides. ② Mark the positions of the bent feet on both sides according to the hole positions. Remove the bent feet and drill two holes with a diameter of  $\phi 6$  and a depth of 1.38~1.57 in. Then install the bent feet and tighten them with M6 self-tapping screws.

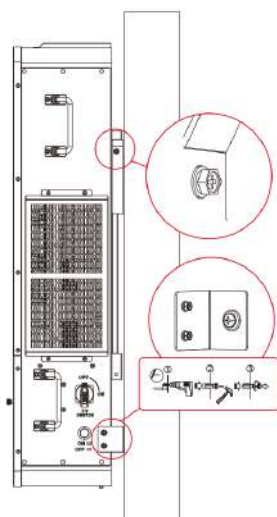

### 3.4 Removing the Terminal Protection Cover

Using a screwdriver, remove the terminal protection cover and anti-insect net.



#### NOTICE

- When using the device in areas with poor air quality, the dust screen is easily blocked by air particles. Please disassemble and clean the dust screen periodically to avoid affecting the internal air flow rate of the inverter, which may trigger an over-temperature protection fault (19/20 fault) affecting the use of the power supply and the service life of the inverter.

## 4 Connection Instructions

### 4.1 Split-Phase Mode

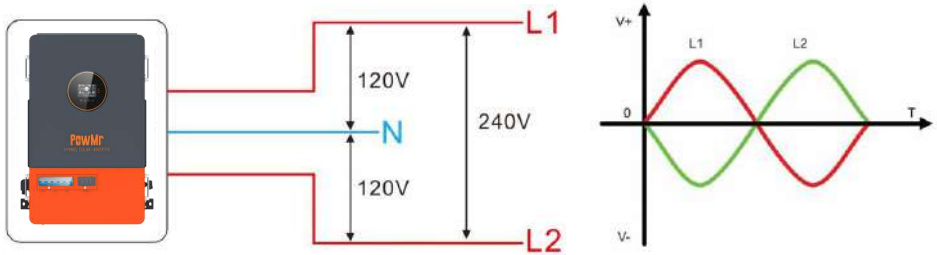

Items	Description
Applicable Model	POW-SunSmart 16KP
AC output phase voltage (L-N)	100-120Vac, 120Vac default
AC output phase voltage (L1-L2)	200-240Vac, 240Vac default

#### NOTICE

- The user can change the output voltage via the settings menu; for details, refer to Chapter 5.3.
- The output voltage corresponds to parameter setting item [38], and the output phase voltage can be set within the range of 200V to 240V.

## Split-phase Mode

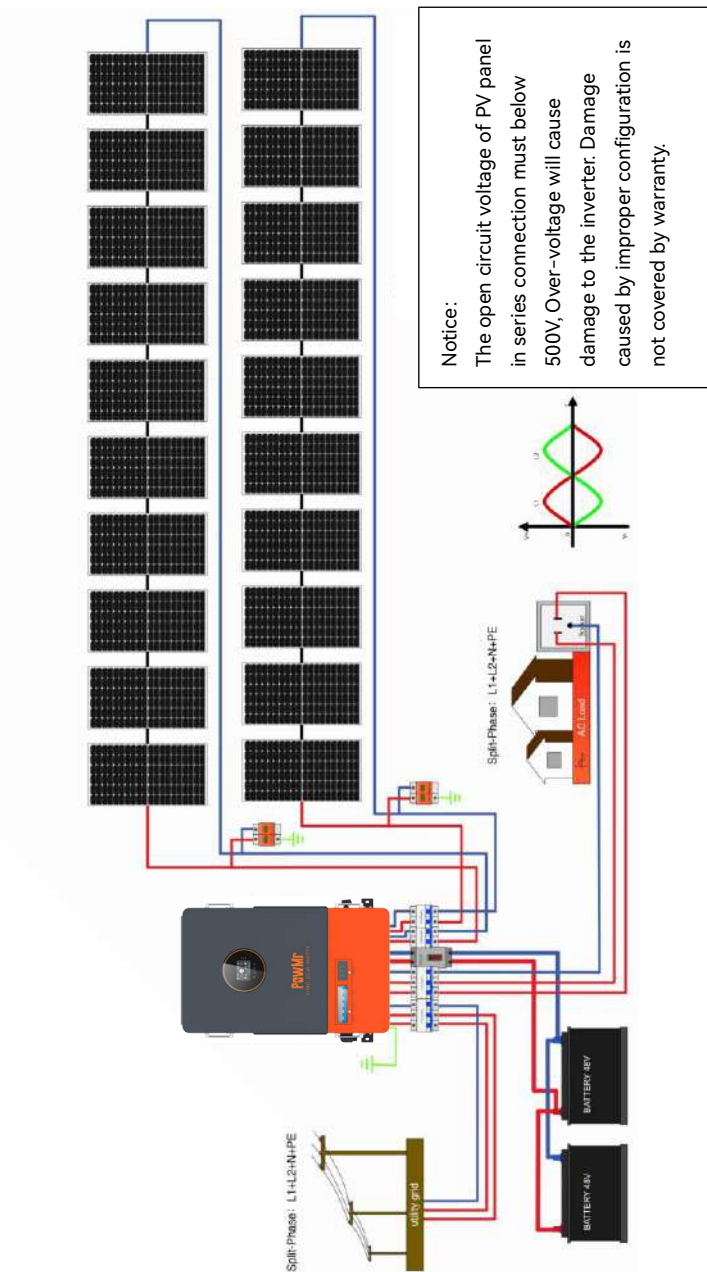

## 4.2 Cable & Circuit Breaker Requirement

- PV Input**

Model	Circuit Count	Cable Diameter	Max. PV Input Current	Circuit Breaker Spec
16KW	PV1	6mm <sup>2</sup> / 10 AWG	36A	2P-45A
	PV2	6mm <sup>2</sup> / 10 AWG	36A	2P-45A

- Battery**

Model	Cable Diameter	Max. Battery Current	Circuit Breaker Spec
16KW	85mm <sup>2</sup> / 000 AWG	300A	2P-350A

- Grid**

Model	Cable Diameter	Max. Input Current	Circuit Breaker Spec
16KW	35mm <sup>2</sup> / 2AWG	100A	3P-125A

- Generator**

Model	Cable Diameter	Max. Input Current	Circuit Breaker Spec
16KW	35mm <sup>2</sup> / 2AWG	66.7A	3P-100A

- Load**

Model	Cable Diameter	Max. Input Current	Circuit Breaker Spec
16KW	35mm <sup>2</sup> / 2AWG	100A	3P-125A

**NOTICE**

● **Grid & Generator input & Load output:**

1. Use a wire stripper to remove 0.55~0.71 in of insulation from the cable.
2. Secure the tubular terminal to the cable end (provided by the user).

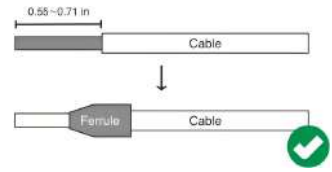

● **PV input:**

1. Use a wire stripper to remove 0.55 in of insulation from the cable.
2. Secure the tubular terminal to the cable end (included in the box).

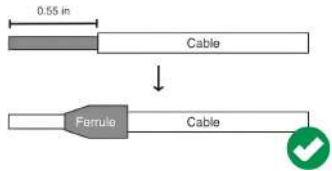

● **Battery:**

1. Use a wire stripper to remove 0.79~0.98 in of insulation from the cable.
2. Fix the cable lugs (provided with the package) at the cable end.

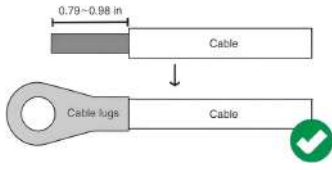

The wire diameter is for reference only. If the distance between the PV array and the inverter or between the inverter and the battery is long, using a thicker wire will reduce the voltage drop and improve the performance of the system.

### 4.3 Grid & Load & Generator Connection

Connect the live, neutral and ground cables in the position and order of the cables as shown in the diagram below.

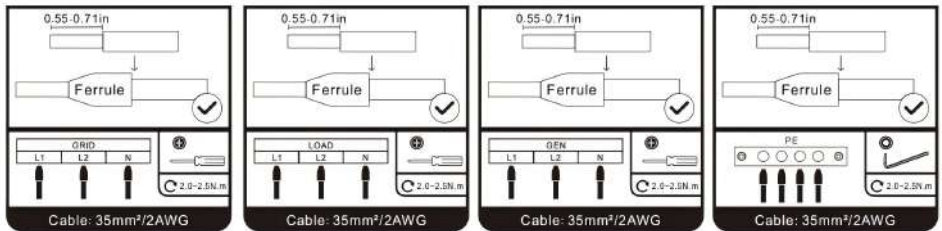
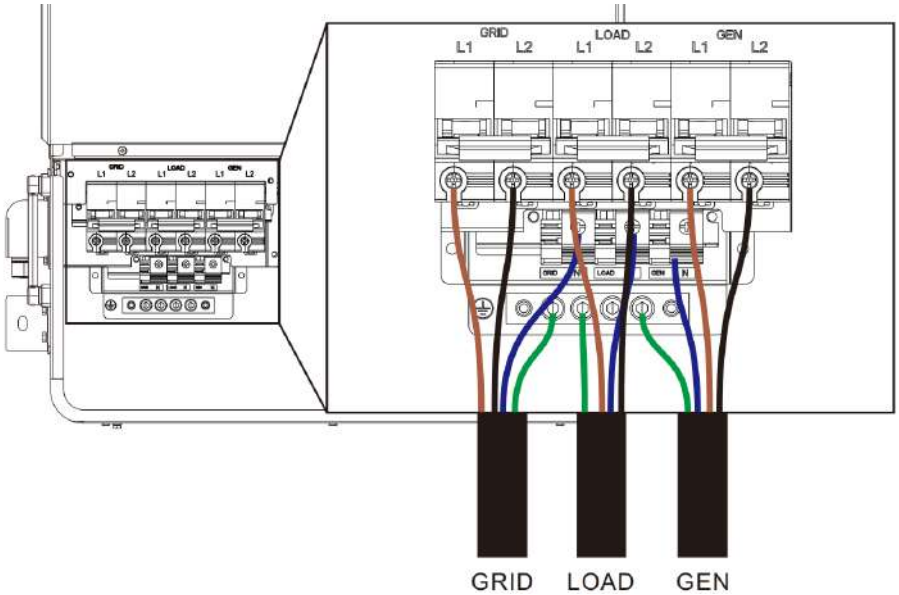

#### DANGER

- Before connecting AC input and output, the circuit breaker must be turned off to avoid electric shock hazards, and never operate with electricity.
- Please check that the cable used is sufficient for the requirements, too thin, poor quality cables are a serious safety hazard.

#### 4.4 Battery Connection

Connect the positive and negative cable of the battery according to the diagram below. Both the positive and negative terminals require the installation of two cables. Each cable is recommended to be 85 mm<sup>2</sup>/ 000 AWG, using crimp terminals SC95-8.

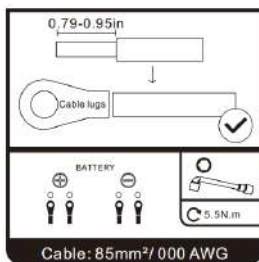
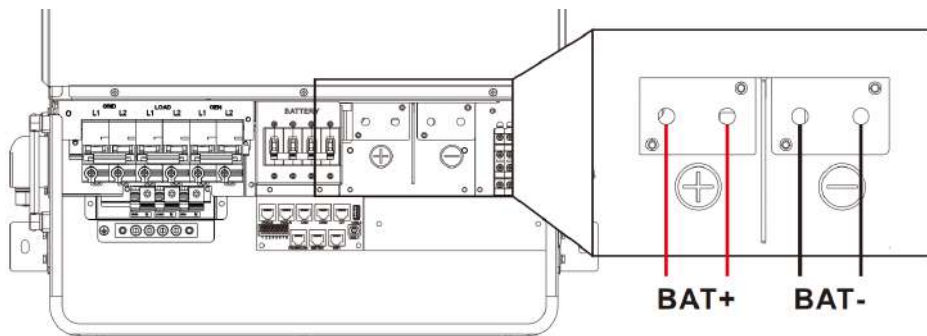

#### DANGER

- Before connecting battery, the circuit breaker must be turned off to avoid electric shock hazards, and never operate with electricity.
- Make sure that the positive and negative terminals of the battery are connected correctly, reversed polarity connection on battery will damage the inverter.
- Please check that the cable used is sufficient for the requirements, too thin, poor quality cables are a serious safety hazard.

## 4.5 PV Connection

Before wiring, disconnect the external circuit breaker first, and confirm whether the cable used is sufficiently thick; Please refer to section "4.2 Cable and Circuit Breaker Selection".

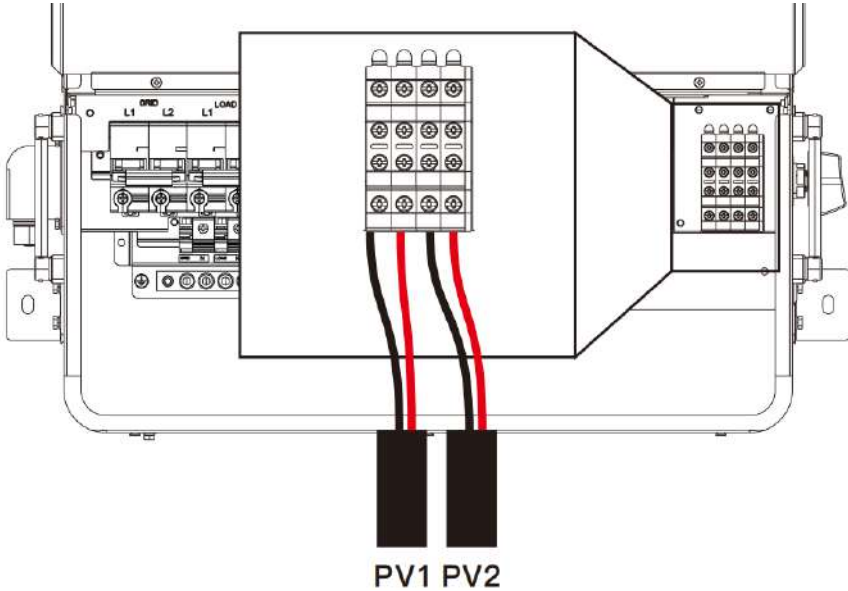

### DANGER

- Before connecting the PV, the circuit breaker must be turned off to avoid electric shock hazards, and never operate with electricity.
- Make sure that the open-circuit voltage of the PV modules connected in series does not exceed the max. open-circuit voltage of the inverter (the value is 600V), otherwise the inverter may be damaged.

### Transmitter-PLC Device (Optional)

The inverter includes a rapid shutdown system that complies with 2017 and 2020 NEC 690.12 requirements. A rapid shutdown switch should be connected to the RSD terminals on the inverter and mounted on a readily accessible location outdoors (check with your AHJ for requirements).

The APsmart Rapid Shutdown System Transmitter-PLC is part of a rapid shutdown solution when paired with APsmart RSD, a PV module rapid shutdown unit. While powered on, the Transmitter-PLC sends a signal to the RSD units to keep their PV modules connected and supplying energy. RSD units automatically enter rapid shutdown mode when the Transmitter-PLC is switched off and resume energy production when power is restored to the Transmitter-PLC.

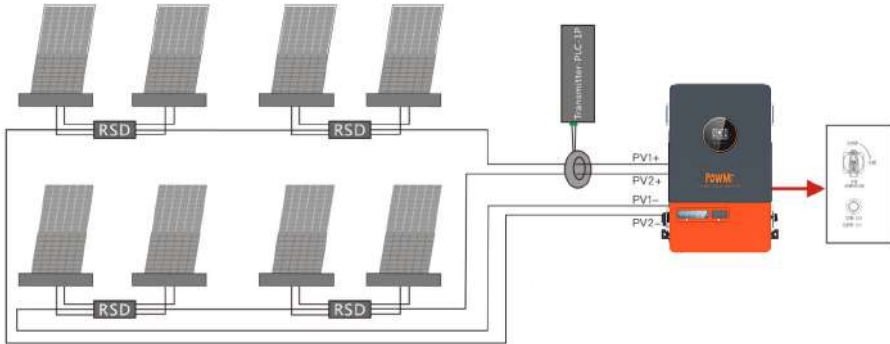

In case of emergency, press the ON/OFF rocker switch button to cut off the RSD power supply, in turn cutting the inverter's AC output along with dropping the PV Conductors voltage to <30V in 30 seconds.

## 4.6 Dry Contact Connection

Use a small screwdriver to push back the direction indicated by the arrow, then insert the communication cable into the dry contact port. (Communication cable diameter 0.2~1.5mm<sup>2</sup>)

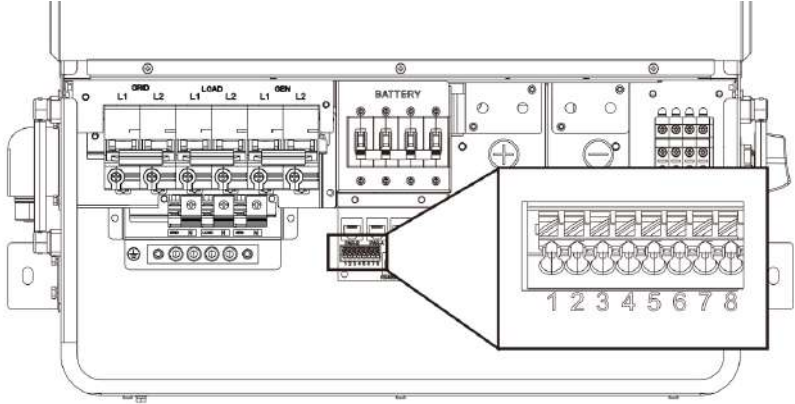

## 4.7 Grounding Connection

Please make sure the grounding terminal connect to the Grounding Bar.

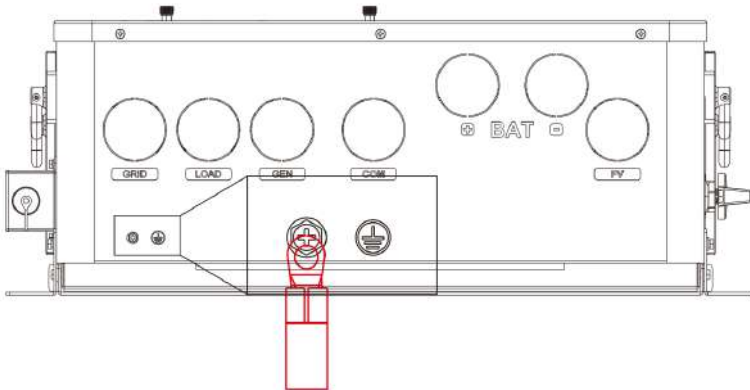

### NOTICE

- The grounding cable should have a diameter of not less than 4 mm<sup>2</sup> and be as close as possible to the grounding point.

---

## 4.8 Inverter Start

After ensuring that the wiring is reliable and the wire sequence is correct, install the terminal protection cover in place.

Step 1: Close the circuit breaker of the battery.

Step 2: Press the ON/OFF switch on the side of the inverter. The screen and indicator lights turning on indicates that the inverter has been activated.

Step 3: Sequential close of the circuit breakers for PV, AC input and AC output.

Step 4: Start the loads one by one in order of power from small to large.

## 5 Operation

### 5.1 Operation and Display Panel

The inverter's operation and display panel includes 1 LCD screen, 3 LED indicators, and 4 operation buttons.

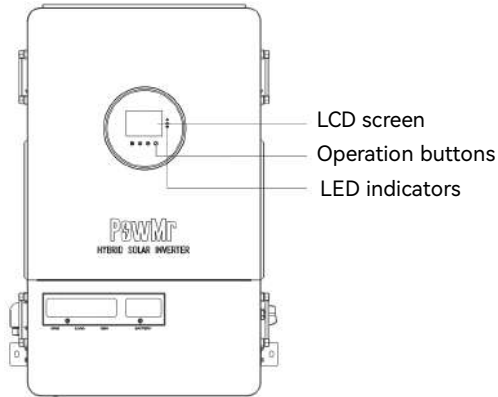

#### ➤ Operation buttons

Button	Description
	To enter/exit the setting menu
	To previous selection
	To next selection
	To confirm/enter the selection in setting menu





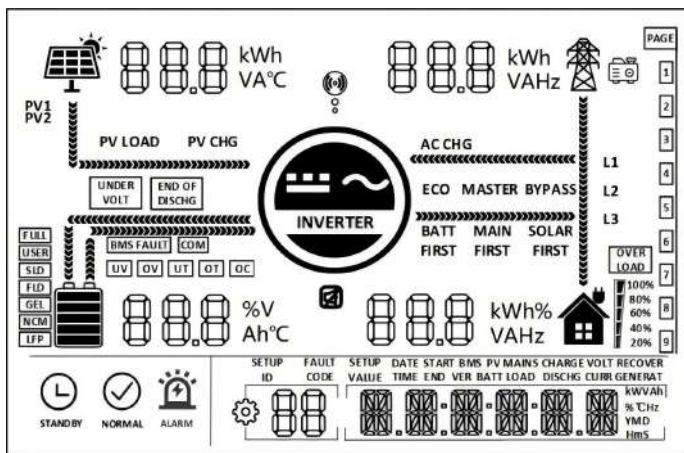

#### ➤ LED indicators

Indicator	Color	Description
AC/INV	Yellow	Steady on: Mains bypass output
		Flashing: Inverter output
CHARGE	Green	Steady on: Charging completed
		Flashing: Charging in progress
FAULT	Red	Flashing: Fault occurred

➤ Display panel



Icon	Description	Icon	Description
	Solar panel		Grid
	Battery		Generator
	Inverter working status		Home load
	The inverter is communicating with the data collector		The buzzer is in mute mode
	Power Flow Direction		
	The inverter is in standby mode		The inverter is working normally
	There is a fault		Settings
	Load power: 80%–100%		SOC: 80%–100%
	Load power: 60%–79%		SOC: 60%–79%

	Load power: 40%–59%		SOC: 40%–59%
	Load power: 20%–39%		SOC: 20%–39%
	Load power: 5%–19%		SOC: 5%–19%
<b>UNDER VOLT</b>	Battery under-voltage	<b>END OF DISCHG</b>	Battery over-discharge
<b>OVER LOAD</b>	Overload	<b>BMS FAULT</b>	BMS fault
<b>COM</b>	System communication error	<b>UV</b>	System under-voltage
<b>OV</b>	System overvoltage	<b>UT</b>	System temperature too low
<b>OT</b>	Too high system temperature	<b>OC</b>	System over-current
<b>FULL</b>	Battery full power	<b>USER</b>	User-defined battery
<b>SLD</b>	Sealed lead-acid battery	<b>FLD</b>	Flooded lead-acid battery
<b>GEL</b>	Gel lead-acid battery	<b>NCM</b>	Ternary Li-ion battery
<b>LFP</b>	LFP Li-ion battery	<b>ECO</b>	Energy-saving mode
<b>PV LOAD</b>	PV energy is carrying the load	<b>PV CHG</b>	PV power is charging the battery
<b>AC CHG</b>	AC input power is charging the battery	<b>MAINS FIRST</b>	The output mode of the inverter is mains first
<b>BYPASS</b>	The output mode of the inverter is mains bypass	<b>SOLAR FIRST</b>	The output mode of the inverter is Solar first
<b>BATT FIRST</b>	The output mode of the inverter is battery first		

## 5.2 View Real-time Data

On the screen, press the UP/DOWN button to view real-time data of the inverter in operation.

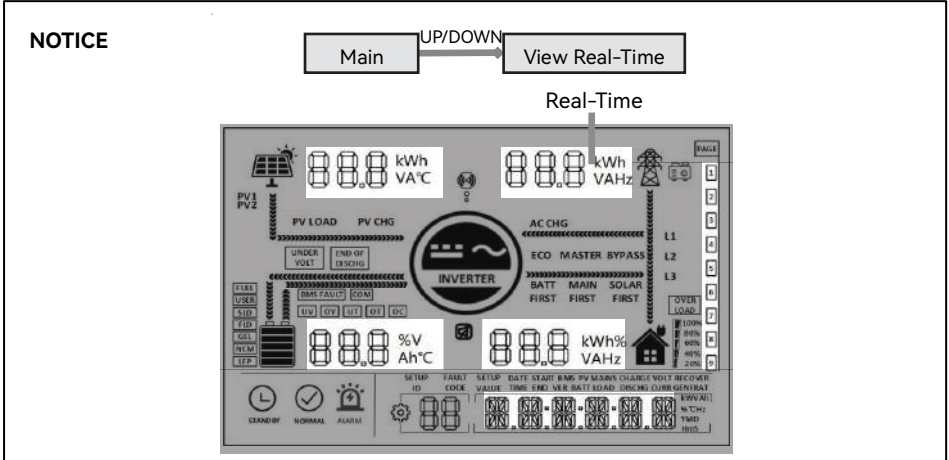

Page	PV	Battery	AC Input	Load	General
1	PV input voltage	Battery voltage	AC input voltage	Load phase voltage	Current time
2	PV input current	Battery current	AC input current	Load phase current	Current date
3	PV input power	Battery power	AC total input power	Load phase active power	Total PV power generation
4	PV daily power generation	BMS battery voltage	AC daily charging capacity	Load phase apparent power	Total load power consumption
5	PV-side heat sink temperature	Battery SOC	AC frequency	AC output frequency	RS485 address
6	INV heat sink temperature	Max. charging current	Bus voltage	UPS phase active power	Main chip software version
7	BAT heat sink temperature	Grid Max. charging current	Grid/diesel generator maximum current	UPS phase apparent power	Slave chip software version
8	/	Diesel generator Max. charging current	Home load active power	Secondary load phase apparent power	Parallel operation mode
9	/	/	/	Secondary load phase apparent power	Customer ID

## 5.3 Setting

### NOTICE

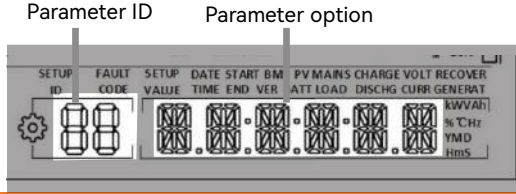
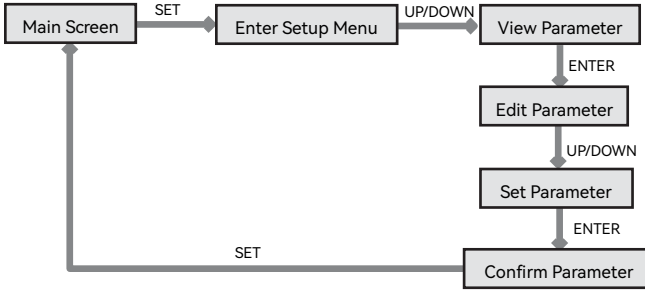

ID	Parameter	Operation	Description
00	Exit	ESC	Exit the setup menu.
01	AC output mode	UTI	PV energy priority with the load, When PV power is insufficient, the grid and PV jointly supply the load. When PV power exceeds the load demand, the surplus charges the battery. Grid charging is activated only when the battery is over-discharged. (parameter item [06] Settings as “OSO(only PV)”, the grid power will not charge), the battery discharges during the scheduled discharge period or when operating in off-grid mode.
		SBU	Prioritizes the use of PV to power the load and switches back to the grid to power the load only when the battery voltage is lower than the set value in parameter item [04] or battery

			<p>under-voltage (When connected to a BMS, the condition will be triggered when the SOC is less than or equal to the value specified in Parameter Item [61] or parameter item [59]). When the battery voltage is higher than the value in parameter item [05] or reaches the preset full-charge threshold (when connected to a BMS, this condition applies when the SOC is greater than or equal to the value of parameter item [62] or parameter item [60]), it switches back to the PV from the grid to supply the load.</p>
		<p>SUB <b>default</b></p>	<p>PV energy first used for charging. When PV is insufficient, the battery will be charged by a combination of the utility and PV power (if parameter item [06] settings as “OSO(only PV)”, The grid energy will not used for charging), and the utility will supply power to the loads simultaneously. When the PV system can fully meet the charging demand, the surplus PV energy will be combined with the utility to supply power to the loads. The battery will discharge during the scheduled discharge period or when operating in off-grid mode.</p>
		<p>SOL</p>	<p>PV first mode. When the PV power is unavailable or the battery voltage is lower than the set value in the parameter item [04] or battery under-voltage, it will switch to the grid mode.</p>
02	AC output frequency	<p>50.0Hz 60.0Hz <b>default</b></p>	<p>In grid mode the AC output frequency will adapt to the grid frequency, otherwise the output will follow the preset values.</p>
03	AC input voltage range	<p>UPS <b>default</b></p>	<p>When the output voltage is 220/230V, the input voltage range is 170–280V.</p>

		APL	When the output voltage is 220/230V, the input voltage range is 90-280V.
04	Voltage point of battery switch to grid	49.2V <b>default</b>	When parameter [01]= SBU/SOL, output source will switch to grid from battery when the battery voltage below the preset value. Setting range: 40~52V.
05	Voltage point of grid switch to battery	56.8V <b>default</b>	When parameter [01]=SBU/SOL, output source will switch to battery from grid when the battery voltage above the preset value. Setting range: 48~60V
06	Battery charging mode	SNU <b>default</b>	PV and grid hybrid charging, with PV charging prioritized. When PV energy is insufficient, mains charging supplements it. When PV energy is sufficient, mains charging stops. Note: PV and grid power can charge the battery simultaneously only when the system is in utility bypass mode. In inverter mode, only PV charging is enabled.
		OSO	Only PV charging, without activating grid charging.
07	Battery charging current	200A <b>default</b>	Setting range: 0~300A
08	Battery type	USER	User-defined, user can set all battery parameter.
		SLd	Sealed lead-acid battery.
		FLd	Flooded lead-acid battery.
		GEL	Gel lead-acid battery.
		L14/ L15/ L16 <b>default</b>	L14/ L15/ L16 lithium iron phosphate batteries, corresponding to lithium iron phosphate batteries 14, 15, 16 series.
		N13/ N14	Ternary lithium batteries, N13/N14, corresponding to ternary lithium batteries 13 series, 14 series.
	No bat	No battery.	

09	Boost charging voltage	56.8V <b>default</b>	Setting range 48V~58.4V, step 0.4V, valid when battery type is user-defined and lithium battery.
10	Boost charging maximum time	120 <b>default</b>	Boost charging maximum time setting, refers to the constant voltage charging when the voltage reaches the parameter [09] setting voltage maximum charging time, set the range of 5min~900min, step of 5 minutes.
11	Battery float charging voltage	56.8V <b>default</b>	Setting range 48V~58.4V, step 0.4V, this parameter can not be set after the BMS communication is successful.
12	Battery over-discharge voltage (delayed shutdown)	48.8V <b>default</b>	When the battery voltage is lower than the judgement point, and triggers the parameter [13], the inverter output is switched off, the setting range is 40V~51V.
13	Battery over-discharge delay time	30 <b>default</b>	The battery voltage is lower than parameter [12], and the inverter output is switched off after triggering the delay time set in this parameter, the setting range is 5s~50s, the step is 5s.
14	Battery under-voltage alarm point	49.6V <b>default</b>	When the battery voltage is lower than this judgement point, the device will under-voltage alarm, the output will not be switched off, the setting range is 40V~52V, the step is 0.4V.
15	Battery discharge limiting voltage	43.2V <b>default</b>	When the battery voltage is lower than this parameter value, the output will be turned off immediately. The setting range is 40V~52V, the step is 0.4V.
16	Battery equalization charging	DIS <b>default</b>	Disable equalization charging.
		ENA	Enable equalization charging, valid when battery type is FLd, SLd, and USER.

17	Battery equalization charging voltage	56.8V <b>default</b>	Setting range 48V~58V in 0.4V steps, valid when battery type is FLd, SLd, and USER.
18	Battery equalization charging duration	120 <b>default</b>	Setting range 5min~900min in 5 min steps, valid when battery type is FLd, SLd, and USER.
19	Battery equalization charging delay time	120 <b>default</b>	Setting range 5min~900min in 5 minute steps, valid when battery type is FLd, SLd, and USER.
20	Battery equalization charging interval	30 <b>default</b>	Setting range 0~30 days in 1 day steps, valid when battery type is FLd, SLd, and USER
21	Battery equalization charging stop-start	DIS <b>default</b>	Start equalization charging immediately.
		ENA	Stop equalization charging immediately.
22	Energy-saving mode	DIS <b>default</b>	Disable energy-saving mode.
		ENA	Enable energy-saving mode, when the load power is less than 25W, the output of the inverter will switch off after a 5-minute delay. When the load exceeds 50W, the inverter will restart automatically.
23	Overload automatic restart	DIS	Disable overload automatic restart, if an overload occurs to shut down the output, the machine will not be restored to power on again.
		ENA <b>default</b>	Enable overload automatic restart. If an overload occurs that shuts down the output, the machine delays for 3 minutes before restarting the output. After accumulating 5 times, it will not restart again.
25	Buzzer alarm	DIS	Disable buzzer alarm.
		ENA <b>default</b>	Enable buzzer alarm.
26	Mode change alarm	DIS	Disable alarm prompt when the status of the main input source changes.
		ENA <b>default</b>	Enable alarm prompt when the status of the main input source changes.

27	Inverter overload switch to bypass	DIS	Disable automatic switching to grid to power the load when the inverter is overloaded.
		<b>ENA default</b>	When the inverter is overloaded, it automatically switches to grid to power the load.
28	Grid charging current	150A <b>default</b>	Setting range: 0~300A.
29	BMS fault causes the battery to stop working.	<b>DIS default</b>	Disable BMS Faulty battery stops working.
		ENA	Enable BMS Faulty battery stops working.
30	RS485 communication address	ID: 1	RS485 address setting range: 1~254.
31	Parallel mode (turn off the rocker switch can be set)	<b>SIG default</b>	Single inverter operation
		PAL	Parallel operation
		3P1/3P2/3P3	Three-phase parallel operation
		<p>P1 Machine Settings: Screen set to “3P1”. When the output phase voltage is selected as “120V”, the output voltage between L1 and L2 is 208V, the voltage between L1 and N is 120V, and the voltage between L2 and N is 120V.</p> <p>P2 Machine Settings: Set the screen to “3P2”. When the output phase voltage is selected as “120V”, the output voltage between L1 and L2 is 208V, the voltage between L1 and N is 120V, and the voltage between L2 and N is 120V.</p> <p>P3 machine settings: Screen set to “3P3”. When output phase voltage is selected as “120V”, the output voltage between L1 and L2 is 208V, the voltage between L1 and N is 120V, and the voltage between L2 and N is 120V;</p> <p>During three-phase balanced parallel operation: 3P1-L1 is in phase with 3P3-L2, 3P1-L2 is in phase with 3P2-L1, and 3P2-L2 is in phase with 3P3-L1. The phase difference between (3P1-L1, 3P3-L1, 3P2-L1) is 120 degrees.</p>	

32	RS485 communication function	DIS <b>default</b>	Disable the BMS communication function.
		485	RS485 BMS communication function.
		CAN	CAN BMS communication function.
33	BMS communication	When item [32] = 485 / CAN, the corresponding lithium battery manufacturer brand should be selected for communication.	
		WOW <b>default</b>	<p><b>485 protocol:</b> PAC=PACE, RDA=RITAR, AOG=ALLGRAND, OLT=OLITER, CEF=CFE, XWD=SUNWODA, DAQ=DYNESS, WOW=SRNE, PYL=PYLONTECH, POW=POWMr, VOL=VILION, SGP=SGP, GSL=GSL Energy, PYT=Pylon tech 2</p> <p><b>CAN protocol:</b> UZE=YUZE, SGP=SGP, GSL=GSL Energy, PYT=Pylon tech 2, WOW=SRNE</p>
34	On-grid and anti-reverse current	DIS <b>default</b>	Disable this function.
		HOME LOAD	<p>When parameter [01]=UTI, PV energy will be prioritized for load supply. Excess energy will be subject to anti-backflow control, and any remaining excess energy will be used to charge the battery.</p> <p>When parameter [01]=SUB, PV energy will be prioritized for charging. After meeting the battery's requirements, the remaining energy will be used for load supply, and any further excess energy will be subject to anti-backflow control.</p>
35	Battery under-voltage recovery point	52.8V <b>default</b>	When the battery is under-voltage, the battery voltage needs to be higher than this setting value in order to restore the battery inverter AC output, setting range: 44V~54.4V.

37	Battery full charge and recharging recovery point	53.6V <b>default</b>	Inverter stops charging when the battery is full. Inverter resumes charging when the battery voltage below this value. Setting range: 44V~54V.
38	AC output phase voltage (turn off the rocker switch can be set)	120Vac <b>default</b>	Setting range: 100/105/110/115/120/127Vac.
39	Charging current limiting method (when BMS is enabled)	LCSET	The maximum battery charge current is not greater than the set value of [item 07]
		LCBMS <b>default</b>	The maximum battery charge current is not greater than the maximum value of BMS
		LC INV	The maximum battery charge current is not greater than the logical judgment value of inverter
40	1st slot grid start charging	00:00:00 <b>default</b>	Setting range: 00:00:00-23:59:00.
41	1st slot grid end charging	00:00:00 <b>default</b>	Setting range: 00:00:00-23:59:00.
42	2nd slot grid start charging	00:00:00 <b>default</b>	Setting range: 00:00:00-23:59:00.
43	2nd slot grid end charging	00:00:00 <b>default</b>	Setting range: 00:00:00-23:59:00.
44	3rd slot grid start charging	00:00:00 <b>default</b>	Setting range: 00:00:00-23:59:00.
45	3rd slot grid end charging	00:00:00 <b>default</b>	Setting range: 00:00:00-23:59:00.
46	Time slot grid charging function	DIS <b>default</b>	Disable this function.
		ENA	After enabling the Time slot grid charging function, the power supply mode will switch to SBU mode, and the system will switch to utility for charging during the preset charging period or after battery over-discharge. If the

			<p>scheduled discharge function is enabled simultaneously, the system power supply mode will switch to UTI mode: the system will only switch to utility for charging during the preset charging period, and will switch to battery inverter power supply during the preset discharge period or when the utility grid fails.</p>
47	1st slot battery start discharging	00:00:00 <b>default</b>	Setting range: 00:00:00-23:59:00.
48	1st slot battery end discharging	00:00:00 <b>default</b>	Setting range: 00:00:00-23:59:00.
49	2nd slot battery start discharging	00:00:00 <b>default</b>	Setting range: 00:00:00-23:59:00.
50	2nd slot battery end discharging	00:00:00 <b>default</b>	Setting range: 00:00:00-23:59:00.
51	3rd slot battery start discharging	00:00:00 <b>default</b>	Setting range: 00:00:00-23:59:00.
52	3rd slot battery end discharging	00:00:00 <b>default</b>	Setting range: 00:00:00-23:59:00.
53	Time slot battery discharging function	DIS <b>default</b>	Disable this function.
		ENA	<p>Enable the segmented scheduled battery discharge function.</p> <p>When parameter item [01] is set to SBU or SOL mode, the system will switch to inverter power supply during the preset discharge period.</p> <p>When parameter item [01] is set to UTI or SUB mode, the battery will work with the utility grid in hybrid load-supply mode, and the maximum discharge current of the battery will be limited by the value specified in parameter item [78].</p> <p>Note: If the time-segmented battery charging function is enabled simultaneously and the time periods overlap, the system will default to the charging period.</p>

54	Local date	00:00:00 <b>default</b>	YY/MM/DD. Setting range: 00:01:01-99:12:31.
55	Local time	00:00:00 <b>default</b>	Setting range: 00:00:00-23:59:59.
56	Leakage current detection protection	DIS <b>default</b>	Disable detecting Leakage current value.
		ENA	Enable detecting Leakage current value.
57	Stop charging current	3	Charging stops when the charging current is less than this setting (unit: A).
58	Discharging alarm SOC setting	15	Triggers an alarm when the battery SOC is less than the set value (unit: %, valid only when BMS communication is normal).
59	Discharging cut-off SOC setting	5	Stops discharging when the battery SOC is less than the set value (unit: %, valid only when BMS communication is normal).
60	Charging cut-off SOC setting	100	Stops charging when the battery SOC is higher than the set value (unit: %, valid only when BMS communication is normal).
61	Switching to grid SOC setting	10	Switch to grid power when the battery SOC is less than this setting value (unit: %, valid only when BMS communication is normal).
62	Switching to inverter output SOC setting	100	Switches to inverter output mode when SOC is higher than this setting value (unit: %, valid only when BMS communication is normal).
63	N-PE bonding automatic switching function	DIS <b>default</b>	Disable automatic switching of N-PE connections.
		ENA	Enable automatic switching of N-PE connections.
68	AC output phase mode (turn off the rocker switch can be set)	120	120 represents split-phase mode. Assuming the item [38] AC output voltage is 120V, with a phase difference of 120 degrees between L1 and L2, the phase voltage L1-N/L2-N is 120V, and the line voltage L1-L2 is 208V.

		180 <b>default</b>	180 represents split-phase mode. Assuming the AC output voltage of parameter [38] is 120V, with a phase difference of 180 degrees between L1 and L2. Therefore, the phase voltage L1-N/L2-N is 120V, and the line voltage L1-L2 is 240V.
		NO N	Without N-wire(When you set “No N”, the phase difference is 180° default)
70	Insulation impedance detection	DIS <b>default</b>	Disable detecting insulation impedance value.
		ENA	Enable detecting insulation impedance value.
73	Generator charging current setting	300A <b>default</b>	Configurable when the generator is GEN_IN, with a maximum of 300A.
74	Generator power setting	16kW	When the generator is set to GEN_IN, the maximum combined load and charging power of the generator is 16 kW. Setting range: 0~16 kW
76	External CT transformation ratio	2000	Setting range: 0~5000
77	External CT anti-backflow error power	100W <b>default</b>	It can be set between 0W and 500W, which means that in order to prevent power sampling errors, 0-500W of electricity is drawn from the grid to ensure that there is no backflow at all.
78	Battery hybrid load discharging current setting	300A <b>default</b>	Battery discharge hybrid network current. Setting range: 0~300A
79	AFCl enable	DIS <b>default</b>	Disable AFCl function.
		1-10	Enable AFCl function. Detection Threshold: 1-10
80	AFCl fault manual clearing	NULL <b>default</b>	Do not clear.
		CLEAR	Manually clear the AFCl fault.

81	Generator operating mode	GEN IN <b>default</b>	Generator interface used as generator function input.
		AC OUT	Generator interface used as secondary load port output.
82	CT manual enabling	NO CT <b>default</b>	No CT input.
		TO INV	CT direction set to inverter flow as positive direction.
		TO GRD	CT direction set to grid flow as positive direction

**NOTICE**

- Battery voltage setting logic: 【15】 < 【12】 < 【04】 < 【14】 < 【35】 < 【37】 < 【05】 < 【09/11】

**Procedure for Restoring Factory Settings:**

Press and hold the UP and DOWN operation keys simultaneously until the border around the time display begins to flash, indicating that the system has entered factory reset mode. At this point, simply power off the device and restart it to complete the reset successfully. If the factory reset mode is accidentally triggered during operation, press and hold the UP and DOWN keys again until the border around the time display stops flashing, which indicates that the system has successfully exited the factory reset mode.

## 5.4 AC Output Mode

The AC output mode corresponds to parameter setting item 01, which allows the user to set the AC output power source manually.

### ■ Utility Priority, PV Loading Priority 01 UTI

PV energy priority with the load, When PV power is insufficient, the grid and PV jointly supply the load. When PV power exceeds the load demand, the surplus charges the battery. Grid charging is activated only when the battery is over-discharged. (parameter item [06] Settings as “OSO(only PV)”, the grid power will not charge), and the battery is only discharged when off the grid.

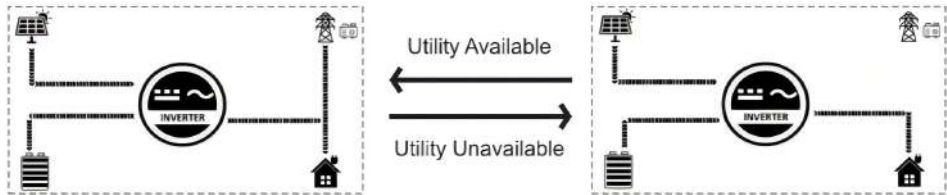

### ■ Utility Priority, PV Charging Priority 01 SUB (default)

PV priority charging; When PV power is insufficient, utility power and PV will perform hybrid charging (when item 06 is set to "PV-only charging", utility power will not be used for charging), and utility power will supply the load. When PV power meets the charging demand but cannot meet the load demand, PV and utility power will perform hybrid loading, and the battery will only discharge in off-grid mode.

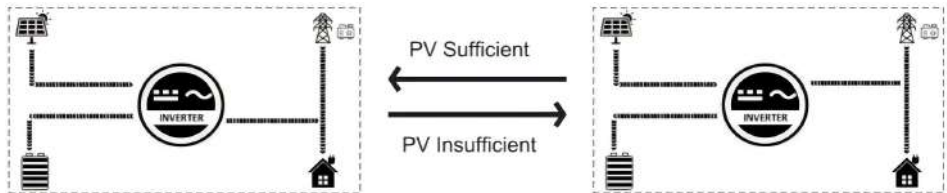

### ■ PV Priority Output 01 SOL

PV prioritizes power supply to the load. When PV meets the load demand, the excess power will charge the battery. When PV energy is insufficient, the battery will supplement energy to power the load. When PV is invalid, it will switch to utility power supply, and finally use battery power supply. When PV energy is insufficient, and when the battery level is lower than the parameter

(Battery to utility) or the SOC setting value for switching to utility, it will switch to utility power supply for the load and charging. PV charges when there is no load. This mode can maximize the use of PV power generation while maintaining battery capacity, and is suitable for areas with stable power grids. (Priority: PV > Utility > Battery)

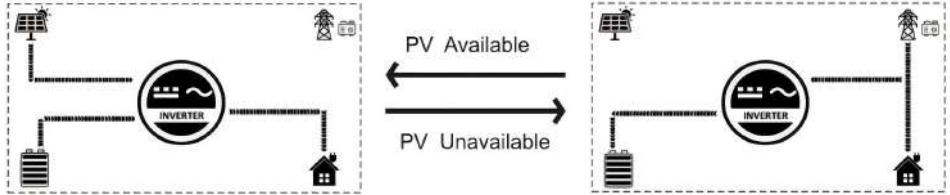

■ Inverter Priority Output 01 SBU

The PV will supply power to the loads on a priority basis. If the PV is insufficient or unavailable, the battery will be used as a supplement to supply power to the load. When the battery voltage touches the value of parameter [04] (Voltage point of battery switch to utility), it will switch to utility power supply to the load (without BMS connected) / When the BMS is connected and the Li-ion battery SOC touches the value of parameter [61] (Switching to utility SOC setting), it will switch to utility power supply to the load. This mode maximizes the use of DC energy, and it is suitable for the areas where the utility power is stable. (Priority: PV > Battery > Utility)

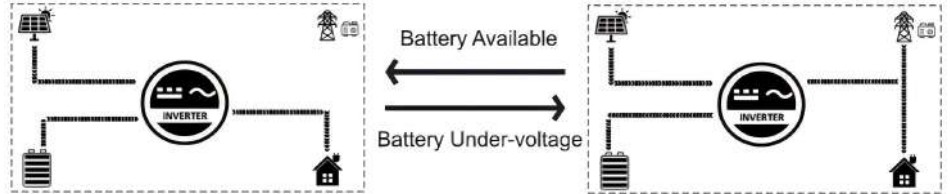

## 5.5 Battery Charging Mode

The charging mode corresponds to parameter [06], which allows the user to set the charging mode manually.

### ■ Hybrid Charging SNU (default)

PV and utility power charge the battery at the same time, with PV taking priority and mains power acting as a supplement when PV is insufficient. This is the fastest charging method and is suitable for areas with insufficient power supply, providing sufficient backup power for users. (Priority: PV > Utility)

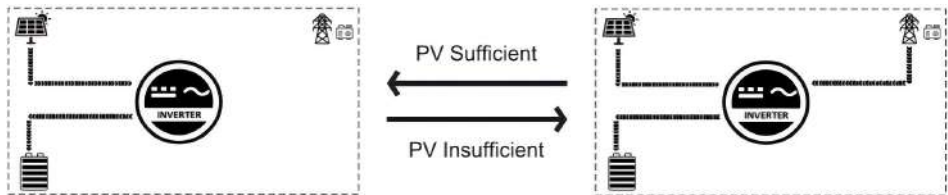

### ■ Only PV Charging OSO

Only PV power is used to charge the battery, without starting the utility charging. This is the most energy-efficient method, with all battery power coming from solar energy, and is usually used in areas with good radiation conditions.

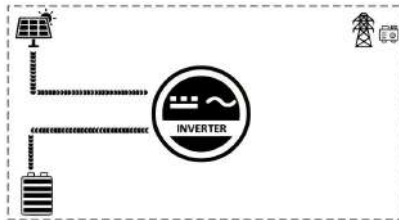

## 5.6 Time-slot Charging/Discharging Function

The product is equipped with time-slot charging/discharging function, users can set different charging/discharging time slots according to the local peak-valley tariff, so as to make efficient use of utility power and PV energy. When the utility price is expensive, the battery can be used to supply power to the loads. When the utility price is cheap, the utility power can be used to supply to the loads and charge, which can help users save the electricity bill to the greatest extent. Users can turn on/off the time-slot charging/discharging function in the setting menu parameters [46] and [53], and set the charging and discharging time periods in parameters [40-45], [47-52] for timed mains charging start/time setting and timed battery discharging start/time setting.

Here is a case example to help users understand the function.

### NOTICE

Before using this function for the first time, please set the local time in parameter [54], [55], then the user can set the corresponding time slot according to the local peak and valley tariff charges.

#### Peak-Valley Electricity Tariff



#### Time-slot Utility Charging/Loading Function

With 3 definable periods, users can freely set the mains charge/loading period in the range of 00:00-23:59. During the user-set periods, solar energy will be prioritized if available. In the absence or insufficiency of solar energy output within the set periods, grid power will be used as a backup.

#### Time-slot Battery Discharging Function

With 3 definable periods, users can freely set the battery discharge period in the range of 00:00-23:59. During the period set by the user, the inverter will first use the battery inverter to load; if the battery power is insufficient, the inverter will automatically switch to mains to ensure stable operation of the load.

## 5.7 Battery Parameters

### ● Lead-acid battery

Parameter \ Battery type	Sealed lead acid battery (SLD)	Gel lead acid battery (GEL)	Flooded lead acid battery (FLD)	User-defined (USE)
Overvoltage Disconnect Voltage	60V	60V	60V	60V
Equalization Charging Voltage	58V	56.8V	58V	40-60V Settable
Boost Charging Voltage	57.6V	56.8V	57.6V	40-60V Settable
Float Charging Voltage	55.2V	55.2V	55.2V	40-60V Settable
Undervoltage Alarm Voltage	44V	44V	44V	40-60V Settable
Undervoltage Disconnect Voltage	42V	42V	42V	40-60V Settable
Discharge Limit Voltage	40V	40V	40V	40-60V Settable
Over-discharge Delay Time	5s	5s	5s	1~30s Settable
Equalization Charging Duration	120min	-	120min	0~600min Settable
Equalization Charging Cycle	30d	-	30d	0~250d Settable
Bulk Charging Cycle	120m	120m	120m	10~900m Settable

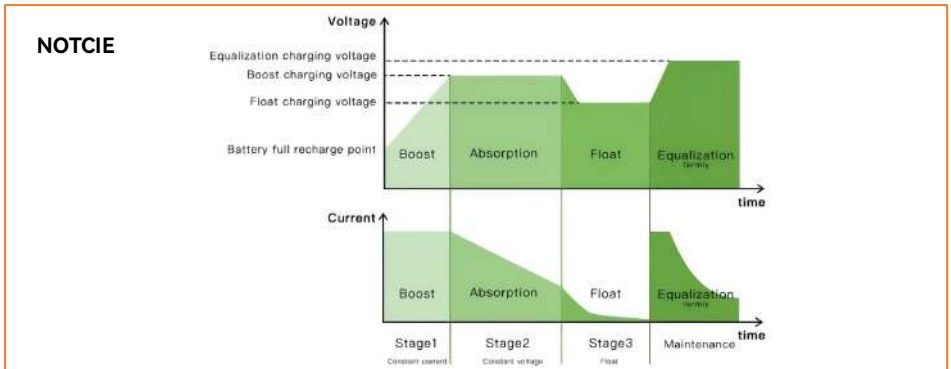

● Lithium-ion Battery

Battery type Parameter	Ternary (N13)	Ternary (N14)	LFP (L16)	LFP (L15)	LFP (L14)	Adjustable
Overvoltage Disconnect Voltage	60V	60V	60V	60V	60V	60V
Equalization Charging Voltage	-	-	-	-	-	40-60V Settable
Boost Charging Voltage	53.2V	57.6V	56.8V	53.2V	49.2V	40-60V Settable
Float Charging Voltage	53.2V	57.6V	56.8V	53.2V	49.2V	40-60V Settable
Undervoltage Alarm Voltage	43.6V	46.8V	49.6V	46.4V	43.2V	40-60V Settable
Undervoltage Disconnect Voltage	38.8V	42V	48.8V	45.6V	42V	40-60V Settable
Discharge Limit Voltage	36.4V	39.2V	46.4V	43.6V	40.8V	40-60V Settable
Over-discharge Delay Time	30s	30s	30s	30s	30s	1-30s Settable
Equalization Charging Duration	-	-	-	-	-	0-600min Settable
Equalization Charging Cycle	-	-	-	-	-	0-250d Settable
Boost Charging Cycle	120min Settable	120min Settable	120min Settable	120min Settable	120min Settable	0-900min Settable

**NOTICE**

If no BMS is connected, the inverter will charge according to the battery voltage with a preset charging curve. When the inverter communicates with the BMS, it will follow the BMS instructions to perform a more complex stage charging process.

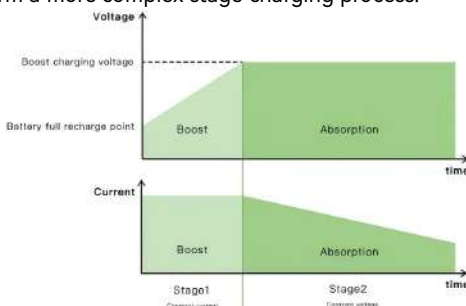

## 6 Communication

### 6.1 Product Overview

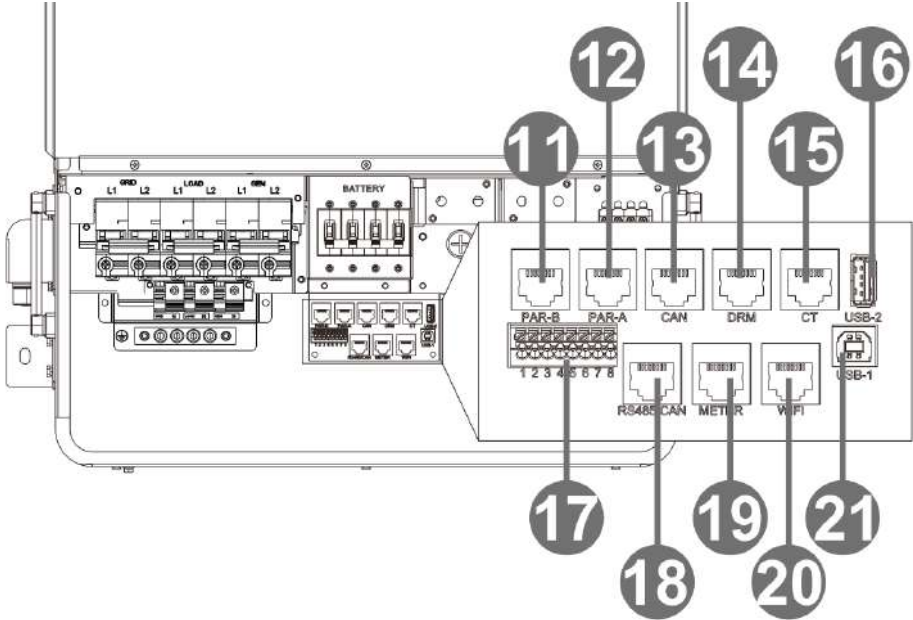

11	Parallel Port (PAR-B)	12	Parallel Port (PAR-A)	13	CAN Port
14	DRM Port (Reserved)	15	CT Port	16	USB-2 Port (Reserved)
17	Dry Contact Port	18	RS485/CAN Port	19	Meter Port
20	WIFI Port 1	21	USB-1 Port		

## 6.2 Parallel Function (For parallel operation only)

This port is a parallel communication port, through which parallel modules can communicate with each other when connected.

1. Each device is equipped with two 8-pin parallel communication ports: PAR-A (Parallel Port A) and PAR-B (Parallel Port B).
2. For connection, connect the PAR-A (Parallel Port A) of the current device to the Parallel Port B of the device to be paralleled, or connect the PAR-B (Parallel Port B) of the current device to the Parallel Port A of the device to be paralleled.
3. Direct connection between the PAR-A and PAR-B of the same device is prohibited.

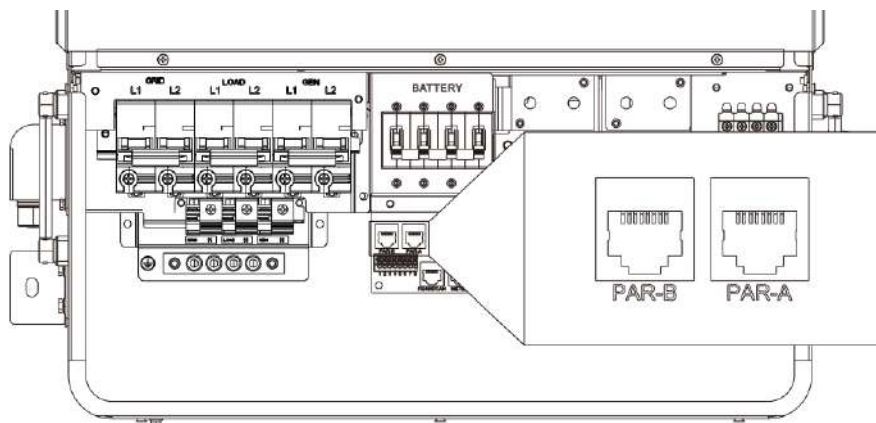

### 6.3 CAN Function

The CAN port is used to connect to the BMS of lithium-ion battery.

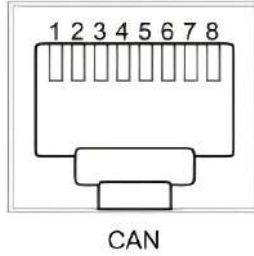

RJ45	Definition
Pin 1	/
Pin 2	/
Pin 3	/
Pin 4	CANH
Pin 5	CANL
Pin 6	/
Pin 7	/
Pin 8	/

## 6.4 RS485/CAN Communication Function

The RS485/CAN communication port is used to connect to the BMS of Li-ion battery.

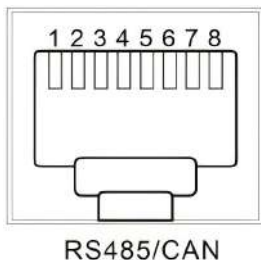

RJ45	Definition
Pin 1	RS485-B
Pin 2	RS485-A
Pin 3	/
Pin 4	CANH
Pin 5	CANL
Pin 6	/
Pin 7	RS485-A
Pin 8	RS485-B

### NOTICE

- If you need to use the inverter to communicate with the lithium battery BMS, please contact us for the communication protocol or upgrade the inverter to the appropriate software program.

**6.5 DRM (Reserved, Only Australia)**

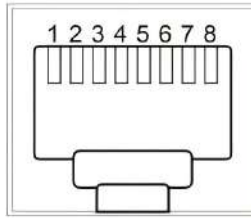

DRM

RJ45	Definition
Pin 1	DRM5
Pin 2	DRM6
Pin 3	DRM7
Pin 4	DRM8
Pin 5	RefGen
Pin 6	COM/DRM0
Pin 7	V+
Pin 8	V-

MODEL	RJ45 socket asserted by shorting pins		Requirement
DRM0	5	6	Operate the power-off device.
DRM5	1	5	Do not generate power to grid.
DRM6	2	5	The power generation shall not exceed 50% of the rated power.
DRM7	3	5	The power generation shall not exceed 75% of the rated power, and reactive power shall be absorbed when possible.
DRM8	4	5	Increase power generation (limited by other active DRM).

### 6.6 External CT Connection

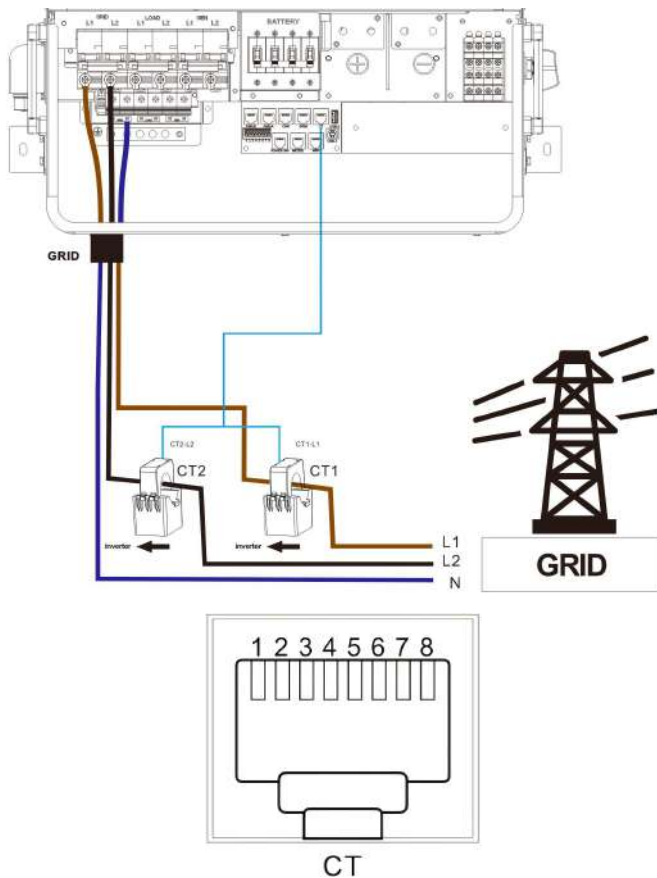

RJ45	Definition
Pin 1	/
Pin 2	/
Pin 3	/
Pin 4	CT2+
Pin 5	CT2-
Pin 6	/
Pin 7	CT1+
Pin 8	CT1-

- ① Split Core Current Transformer (CT) dimension: (mm)
- ② Secondary output cable length is 4m (157.48 in).

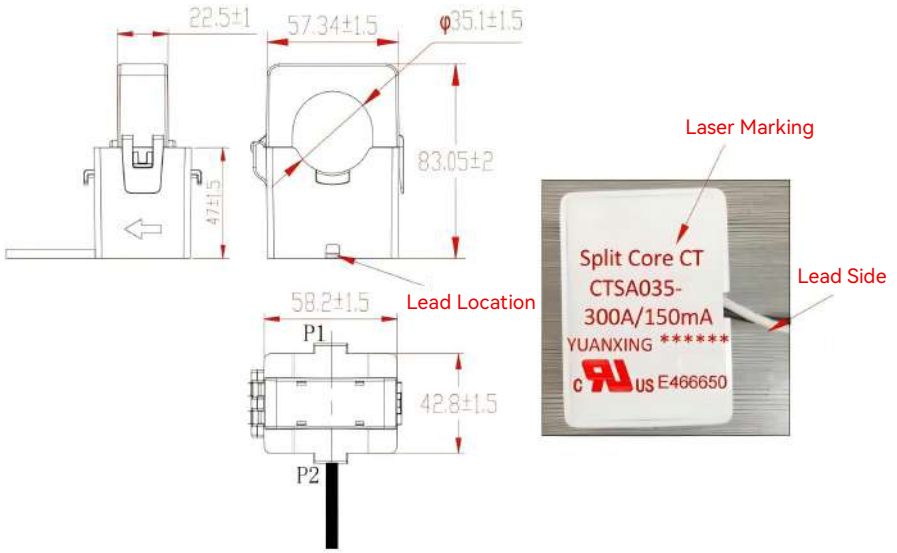

## 6.7 Meter Communication (Optional)

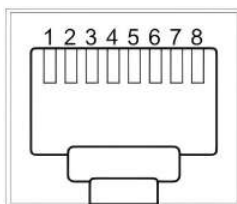
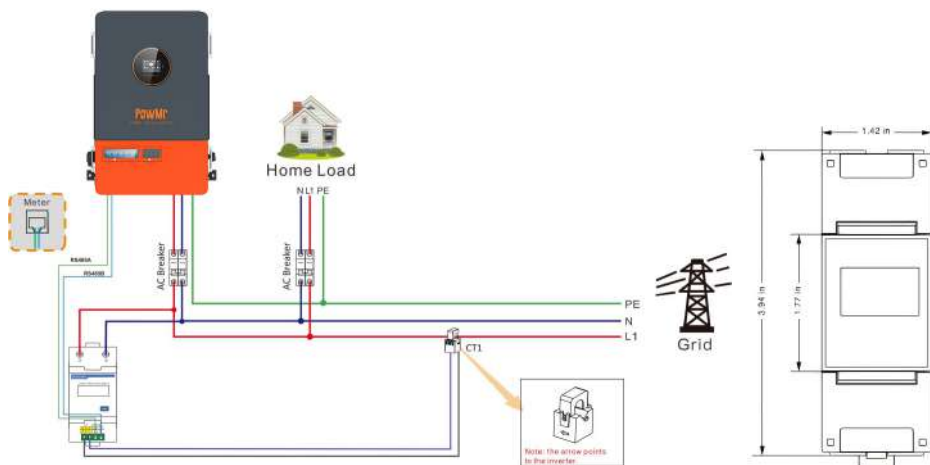

Meter

RJ45	Definition
Pin 1	RS485-B
Pin 2	RS485-A
Pin 3	/
Pin 4	/
Pin 5	/
Pin 6	/
Pin 7	RS485-A
Pin 8	RS485-B

## 6.8 WiFi Communication Function

The WiFi communication port can be connected to the optional RS485-to-WiFi/GPRS communication module developed by our company. After installing this module, it can connect to our inverter, allowing users to view the inverter's operating status and parameters through a mobile APP.

### ➤ WiFi Port 1 (either one)

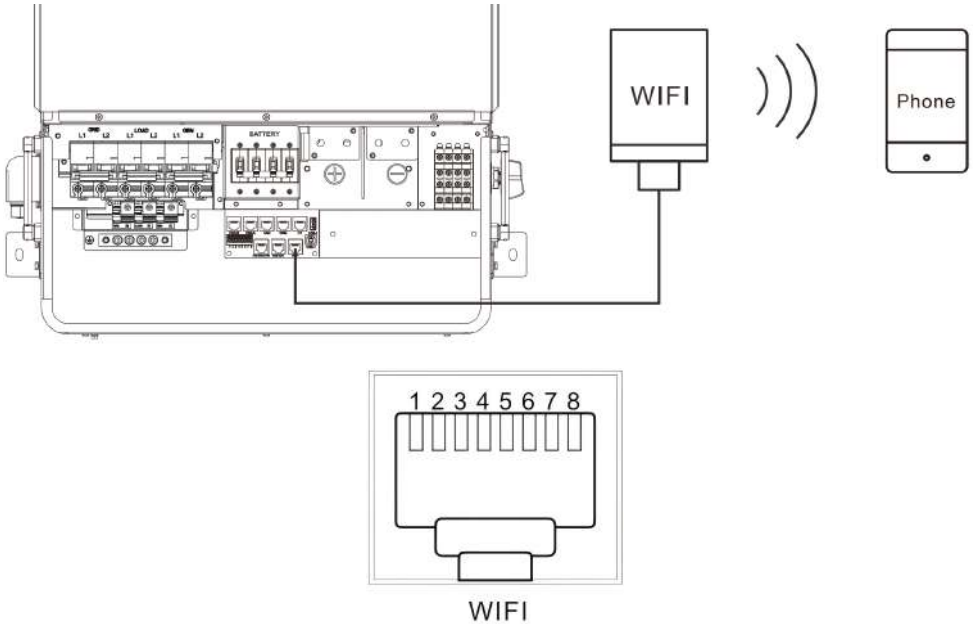

RJ45	Definition
Pin 1	5V
Pin 2	GND
Pin 3	/
Pin 4	/
Pin 5	/
Pin 6	/
Pin 7	RS485-A
Pin 8	RS485-B

➤ WiFi Port 2 (either one)

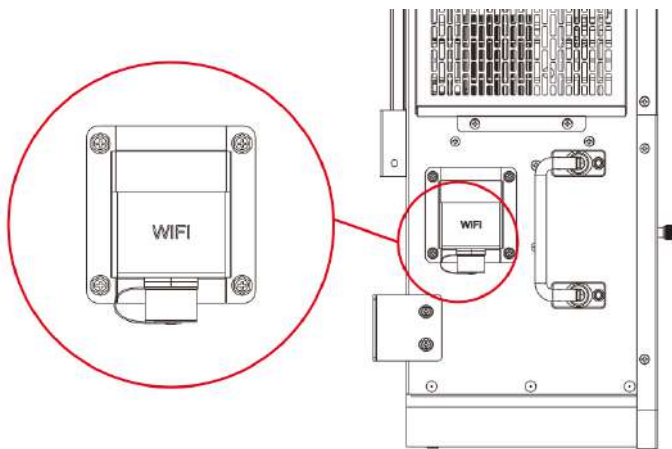

## 6.9 USB-1 Communication Function

Users can use the host computer software to read and modify the device parameters through this port. If you need the installation package of the host computer software, The installation package is available for download on the official website, or you may contact us to get it.

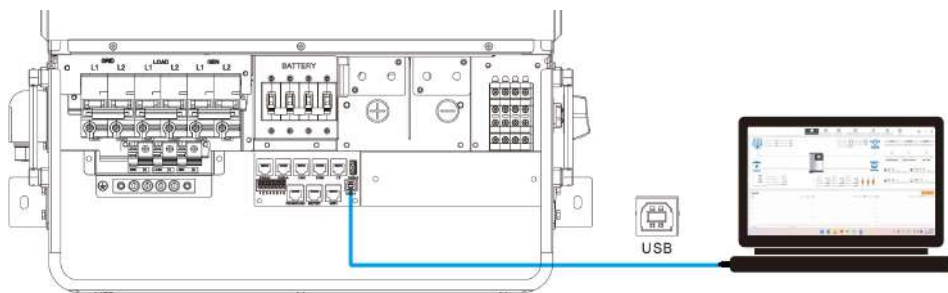

## 6.10 Dry Contact Port

The dry contact port has 5 functions:

1. RSD power supply
2. Remote switch on/off (reserved)
3. Switching signal output (reserved)
4. Battery temperature sampling (reserved)
5. Generator remote start/stop

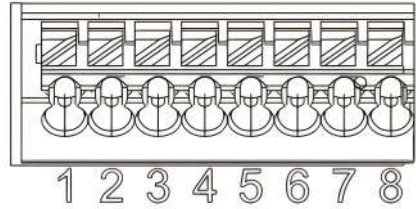

Function	Description
RSD power supply	PIN 1 is GND, PIN 2 is RSD 12V+
Remote switch on/off (reserved)	When pin 1 is connected to pin 3, the inverter will shut off AC output. When pin 1 is disconnected from pin 3, the inverter will resume normal output.
Switching signal output (reserved)	When the battery voltage reaches the battery discharge limit voltage (parameter [15]), the voltage between pin 4 and pin 1 is 0V. When the battery is charging normally, the voltage between pin 4 and pin 1 is 5V.
Temperature sampling (reserved)	Pin 1 & Pin 5 can be used for battery temperature sampling compensation.
Generator remote switch	When the battery voltage reaches the battery under-voltage alarm point (Parameter item [14]) or the voltage point for switching to mains power (Parameter item [04]), pins 7 to 6 are normally open, and pins 8 to 6 are normally closed. When the battery voltage reaches the voltage point for switching to mains power (parameter [05]) or the battery is fully charged, pins 7 to 6 are normally closed, and pins 8 to 6 are normally open. (Pins 6/7/8 output 125Vac/1A, 230Vac/1A, 30Vdc/1A).

### NOTICE

- If you need to use the remote start/stop function of the generator with dry contact, please ensure that the generator has an ATS and supports remote start/stop.

## 7 Fault Codes and Response Measures

### 7.1 Fault Codes

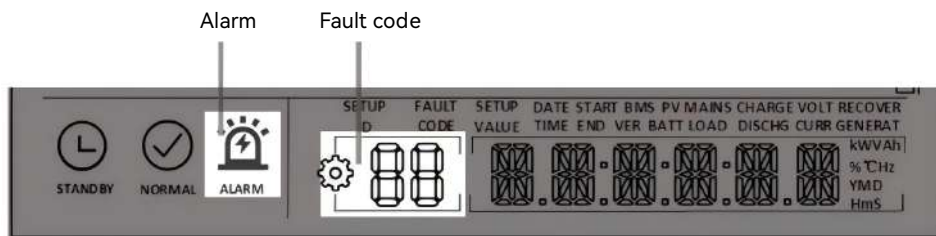

Fault Code	Meaning	Does it Affect the outputs	Description
01	BatVoltLow	No	Battery undervoltage alarm
02	BatOverCurrSw	Yes	Battery discharge average current overcurrent (software protection).
03	BatOpen	Yes	Battery not-connected alarm.
04	BatLowEod	Yes	Battery undervoltage stop discharge alarm.
05	BatOverCurrHw	Yes	Battery overcurrent (hardware protection).
06	BatOverVolt	Yes	Charging overvoltage protection.
07	BusOverVoltHw	Yes	Bus overvoltage (hardware protection).
08	BusOverVoltSw	Yes	Bus overvoltage (software protection).
09	PvVoltHigh	No	PV overvoltage protection.
10	PvAFCIErr	No	PV arc fault.
11	PvOCHw	No	Boost overcurrent (hardware protection).
12	SpiCommErr	Yes	SPI communication fault of master and slave chips.

13	OverloadBypass	Yes	Bypass overload protection
14	OverloadInverter	Yes	Inverter overload protection
15	AcOverCurrHw	Yes	Inverter overcurrent (hardware protection)
16	AuxDspReqOffPWM	Yes	Slave chip OFF request fault.
17	InvShort	Yes	Inverter short-circuit protection.
18	Bussoftfailed	Yes	Bus soft-start failure.
19	OverTemperMppt	No	PV radiator over-temperature protection.
20	OverTemperInv	Yes	Inverter radiator over-temperature protection.
21	FanFail	Yes	Fan blockage or failure fault.
22	EEPROM	Yes	Memory failure.
23	ModelNumErr	Yes	Model setting error.
24	Busdiff	Yes	Positive and negative bus voltage imbalance.
25	BusShort	Yes	Busbar short circuit.
26	Rlyshort	Yes	Inverted AC Output Backfills to Bypass AC Input.
27	LinePhaseLose	Yes	Grid input phase lose.
28	LinePhaseErr	Yes	Grid input phase error.
29	BusVoltLow	Yes	Bus voltage undervoltage protection.
30	BatCapacityLow1	No	Alarm given when battery capacity rate is lower than 10% (setting BMS to enable validity).
31	BatCapacityLow2	No	Alarm given when battery capacity rate is lower than 5% (setting BMS to enable validity).

32	BatCapacityLowStop	Yes	Inverter stops when battery capacity is low (setting BMS to enable validity).
33	ControlCanFault	Yes	Control CAN fault in parallel operation.
34	CanCommFault	Yes	CAN communication fault in parallel operation.
35	ParaAddrErr	Yes	Parallel ID (communication address) setting error.
36	Balance currentOC	Yes	Balanced bridge arm overcurrent fault.
37	ParaShareCurrErr	Yes	Parallel current sharing fault.
38	ParaBattVoltDiff	Yes	Large battery voltage difference in parallel mode.
39	ParaAcSrcDiff	Yes	Inconsistent AC input source in parallel mode.
40	ParaHwSynErr	Yes	Hardware synchronization signal error in parallel mode.
41	InvDcVoltErr	Yes	Inverter DC component of voltage abnormality.
42	SysFwVersionDiff	Yes	Inconsistent parallel operation program versions.
43	ParaLineContErr	Yes	Parallel wiring fault.
44	Serial number error	Yes	Serial number not set at factory.
45	Error setting of split-phase mode	Yes	[31] Incorrect settings for parallel operation mode.
46	MeterComErr	Yes	Meter communication error.
48	AFCIComErr	Yes	AFCI communication error.
56	Low insulation resistance fault	No	PV1+, PV2+ and PV- abnormally low impedance to ground.
57	Leakage current overload fault	Yes	System leakage current exceeds limit.

58	BMS communication error	No	BMS communication error.
60	BMS battery low temperature alarm	No	BMS low temperature alarm (effective after successful BMS communication).
61	BMS battery over temperature alarm	No	BMS over-temperature alarm (effective after successful BMS communication).
62	BMS battery over current alarm	No	BMS overcurrent alarm (effective after successful BMS communication).
63	BMS battery undervoltage alarm	No	BMS undervoltage alarm (effective after successful BMS communication).

## 7.2 Trouble Shooting

Fault Code	Meaning	Cause	Solution
/	No screen display	No power input, or the switch on the bottom of the unit is not switched on.	Check whether the battery air circuit-breaker or PV air circuit-breaker is turned on. Check if the switch is "ON". Press any button on the screen to exit the screen sleep mode.
01	Battery under-voltage	The battery voltage is lower than the value set in parameter [14].	Charge the battery until the battery voltage exceeds the set value in parameter [14].
03	Disconnected battery	The battery is not connected, or the BMS of the lithium-ion battery is in the discharge protection state.	Check whether the battery is reliably connected. Check if the battery circuit breaker is closed. Ensure that the BMS can communicate normally.
04	Battery over-discharge	The battery voltage is lower than the value set in parameter [12].	Manual reset: Turn off and restart the device. Automatic reset: Charge the battery to make the battery voltage higher than the value set in parameters [35].
06	Battery over-voltage when charging	The battery is in the overvoltage state.	Manually turn off the power and restart. Check if the battery voltage exceeds the limit value. If it does, the battery needs to be discharged until the voltage is lower than the battery overvoltage recovery point.
13	Bypass over-load (software detection)	The output power or current of the bypass is overloaded within a certain period.	Reduce the load power and restart the device. For details, please refer to item 11 of the protection functions.
14	Inverter overload (software detection)	The output power or current of the inverter is	

		overloaded within a certain period	
19	Over-high temperature of the heat sink for PV input (software detection)	The temperature of the heat sink for PV input exceeds 90°C for 3s	When the temperature of the heat sink cools below the over-temperature recovery threshold, normal charging and discharging resume.
20	Over-high temperature of the heat sink for inverter output (software detection)	The temperature of the heat sink for inverter output exceeds 90°C for 3s	
21	Fan failure	Software detection finds the fan has a fault.	After turning off the machine's power, manually switch the fan and check for any foreign objects blocking it.
26	AC Input relay short-circuit	Stuck relay for AC output	Manually turn off and restart the machine, if the fault reappears after restarting, you need to contact the after-sales service to repair the machine.
28	Mains input phase fault	The phase of AC input is inconsistent with that of AC output	Ensure that the phase of AC input is the same as that of AC output. For example, if the output is in the split-phase mode, the input shall also be in the split-phase mode.

**NOTICE**

- If you encounter product faults that cannot be solved by the methods listed in the above table, please contact our after-sales service department for technical support, and do not disassemble the device by yourself.

## 8 Protection Function and Maintenance

### 8.1 Protection Function

No.	Protection Functions	Description
1	PV current-limiting protection	When the configured PV array charging current or power exceeds the rated PV input value, the inverter will limit the input power and charge at the rated value.
2	PV overvoltage protection	If the PV voltage exceeds the maximum value allowed by the hardware, the device will report a fault and stop PV boosting to output a sinusoidal AC waveform.
3	Anti-reverse charge protection at night	At night, the battery will be prevented from discharging to the PV module because the battery voltage is greater than the PV module voltage.
4	Mains input over-voltage protection	When the mains voltage exceeds 140Vac, mains charging will stop and the inverter will switch to output mode.
5	Mains input under-voltage protection	When the mains voltage falls below 90Vac, mains charging will stop and the inverter will switch to output mode.
6	Battery over-voltage protection	When the battery voltage reaches the over-voltage disconnection voltage point, it will automatically stop the PV and grid charging of the battery to prevent over-charging and damage to the battery.
7	Battery under-voltage protection	When the battery voltage reaches the low-voltage disconnection voltage point, it will automatically stop discharging the battery to prevent the battery from being over-discharged and damaged.
8	Battery over-current protection	When the battery current exceeds the range allowed by hardware, the machine will turn off output and stop discharging the battery.
9	AC output short-circuit protection	When a short-circuit fault occurs at the load output terminal, it will immediately turn off the output of AC voltage. Only after manually powering on the device, normal output restores.

10	Heat sink over-temperature protection	When the internal temperature of the inverter is too high, the inverter will stop charging and discharging; when the temperature returns to normal, the inverter will resume charging and discharging.
11	Overload protection	After overload protection is triggered, the inverter output will be restored after 3 min, and after 5 times of overload, the output will be off until the frequency changer is restarted. (102%< load <110%): An error will be reported, and the output will be turned off after 5 min. (110%< load <125%): An error will be reported, and the output will be turned off after 10s.
12	AC backward protection	Prevent the mains of battery inverter backward to bypass AC input
13	Bypass over-current protection	Built-in circuit breaker for AC input overcurrent protection.
14	Bypass wiring error protection	When the phase of the two bypass inputs is different from that of the inverter split-phase, the machine will prohibit connecting to the bypass, thus preventing the power failure or short circuit of load when connecting to the bypass.

## 8.2 Maintenance

**To maintain optimal long-term performance, it is recommended to perform the following inspections twice a year for inverter systems:**

1. Ensure that the airflow around the inverter is not blocked and remove any dirt or debris from the radiator.
2. Check that all exposed conductors are not damaged by sunlight, friction with other surrounding objects, dry rot, insect or rodent damage, etc. The conductors need to be repaired or replaced if necessary.
3. Verify that the indications and displays are consistent with the operation of the equipment, note any faults or incorrect displays and take corrective action if necessary.
4. Check all terminals for signs of corrosion, insulation damage, high temperatures or burning/discoloration and tighten terminal screws.
5. Check for dirt, nesting insects and corrosion, clean as required, Clean the insect screen regularly.
6. If the lightning arrester has failed, replace the failed arrester in time to prevent lightning damage to the inverter or other equipment of the user.

### **DANGER**

- Before conducting any inspection or operation, please ensure that the inverter is disconnected from all power sources and that the capacitor is fully discharged to avoid the risk of electric shock.

### 8.3 Storage

**If the inverter is not to be put into use immediately, the following requirements shall be met for storage:**

- Do not remove the original packaging of the inverter.
- The storage temperature shall be maintained at  $-13\sim 140^{\circ}\text{F}$ ; the relative humidity shall be maintained at 5%~95% RH.
- Store in a clean and dry place to protect against dust and moisture erosion.
- Maximum stacking height: 5 layers. When stacking, place the inverters with care to prevent tipping over, which may cause personal injury or equipment damage.
- Conduct regular inspections during storage (recommended once every three months). Replace the packaging materials in a timely manner if moth damage, rat bites or packaging damage is found.
- If the storage period is 2 years or longer, the inverter must be inspected and tested by professional personnel before being put into use.

## 9 Parameter Table

MODEL	POW-SunSmart 16KP	Adjustable
<b>AC Output</b>		
Rated Output Power	16000W	
Max. Peak Power	2 times rated power, 10s	
Max. Apparent Power	16000VA	
Rated Output Voltage	120Vac/240Vac (L1+L2+N+PE)	
Rated Output Current	66.7Aac	
Motor Load Capacity	9HP	
Rated Output Frequency	50/60Hz	√
Waveform	Pure sine wave	
Switch Time	10 ms (typical)	
<b>Battery Data</b>		
Battery Type	Lead-Acid Battery/Lithium-Ion Battery/ User-Defined	√
Rated Battery Voltage	48Vdc	
Battery Voltage Range	40-60Vdc	
Max. Grid/Generator Charging Current	300Aac	√
Max. Charging/Discharging Current	300Aac	√
Charging Curve	3 Stages / Equalization	
Charging Strategy for Li-ion Battery	Self-adaption to BMS	
<b>PV Input</b>		
No. of MPPT Trackers	2	
Max. PV Input Power	12000W + 12000W	
Max. PV Input Current	36Aac + 36Aac	
PV Short-circuit Current	50Aac + 50Aac	
PV Start-up Voltage	90Vdc / 90Vdc	

Max. PV Open-Circuit Voltage	600Vdc / 600Vdc	
MPPT Operating Voltage Range	120-550Vdc / 120-550Vdc	
<b>Grid/Generator Input</b>		
Rated Input Voltage	120Vac/240Vac (L1+L2+N+PE)	
Input Voltage Range	85-140Vac / 170-280Vac	
Rated Input Frequency	50/60Hz	
Charging Current Error	2%	
Bypass Overload Current (Grid)	100Aac	
Bypass Overload Current (Generator)	66.7Aac	
<b>Efficiency</b>		
MPPT Tracking Efficiency	>99%	
Max. Inverter Efficiency	94.3%	
Max. Charging Efficiency	93.4%	
<b>General Data</b>		
Parallel Capacity	1~6 units	
Dimensions (L × W × H)	20.24×8.46×33.41 in	
Weight	105 lbs	
Protection Degree	IP20, indoor use only	
Operating Temperature	14~131 °F, >113 °F Derated	
Noise	<60dB	
Altitude	78740 in	
Cooling Method	Intelligent Air Cooling	
<b>Communication</b>		
Internal Interface	RS485 / CAN / WiFi / Dry contact	√
External Module (optional)	Wi-Fi / 4G Stick	√
<b>Certification</b>		
Safety Standards	IEC62109-1, IEC62109-2, UL1741	
EMC	EN61000-6-1, EN61000-6-3	

---

**Protection**

Has PV Current Limiting Protection, PV Overvoltage Protection, Night Anti-backcharging Protection, Mains Input Overvoltage Protection, Mains Input Undervoltage Protection, Battery Overvoltage Protection, Battery Undervoltage Protection, Battery Overcurrent Protection, AC Output Short-circuit Protection, Heat Sink Overtemperature Protection, Overload Protection, AC Backfeed Protection, Bypass Overcurrent Protection, Bypass Wiring Error Protection, Arc Fault Protection, Leakage Current Protection, Rapid Shutdown Signal Generator (Optional), AFCI/GFCI/RSD (Optional)

---

## 10 Appendix I: Parallel Connection

### 10.1 Parallel Operation

1. Up to 6 units connected in parallel.
2. When using the parallel operation function, the following connecting lines (package accessories) shall be firmly and reliably connected.

#### Parallel communication cable\*1

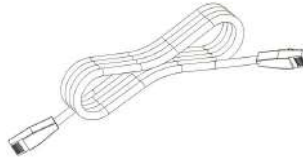

### 10.2 Precautions for Connecting Parallel Connection Cables

#### 1. PV connection:

When connecting in parallel, the PV arrays connected to each inverter must be independent of each other. The PV arrays corresponding to PV1, PV2 ports of the same inverter must also be independent.

#### 2. Battery connection:

When connecting in parallel, all solar energy storage inverters must be connected to the same battery, with BAT+ connected to BAT+ and BAT- connected to BAT-. Before powering on and starting, it is necessary to check and ensure that the connections, wiring length, and cable size are correct to prevent abnormal operation of the parallel system output caused by incorrect connections.

#### 3. Load connection:

All solar storage inverters must be connected in the manner of N-to-N and PE-to-PE. The L lines of all inverters in the same phase shall be connected together, but the AC output L lines of different phases shall not be connected together. Refer to the schematic diagram for wiring.

#### 4. Grid connection:

All solar storage inverters must be connected in the manner of N-to-N and PE-to-PE. The L lines of all inverters in the same phase shall be connected together, but the AC input L lines of different phases shall not be connected together. Refer to the schematic diagram for wiring.

**5. Communication Lines:**

Our parallel communication cable is a shielded 8-pin network cable suitable for parallel connections. Each unit must have one input and one output connection. In a parallel system, the "Parallel A" interface of this machine must be connected to the "Parallel B" interface of the target machine. It is strictly prohibited to connect the "Parallel A" interface of this machine to either the "Parallel B" interface of the same machine or the "Parallel A" interface of the target machine. Additionally, secure each unit's parallel communication cable firmly to the 8-pin network connector to prevent disconnections or poor contacts, which may lead to abnormal system operation or damage to the output.

- 6.** Before and after connecting the system, carefully refer to the system wiring diagram below. Ensure all connections are correct and secure before powering on.
- 7.** After the system is correctly wired, powered on, and operating normally, if a new inverter needs to be connected, ensure that the battery input, PV input, AC input, and AC output are disconnected, and all solar energy storage inverters are powered off before reconnecting to the system.

### 10.3 Wiring diagram for split-phase parallel connection (phase difference between L1 and L2: 180°)

Set the item [31] to PAL, and set the item [68] to 180°. When setting the item [38] to "120 V," the L1-L2 voltage is 240 V, and the L1-N voltage is 120 V, L2-N voltage is 120V. When multiple units are operating in parallel, the schematic diagram for parallel connection guidance is as follows:

**a) Two units connected in parallel:**

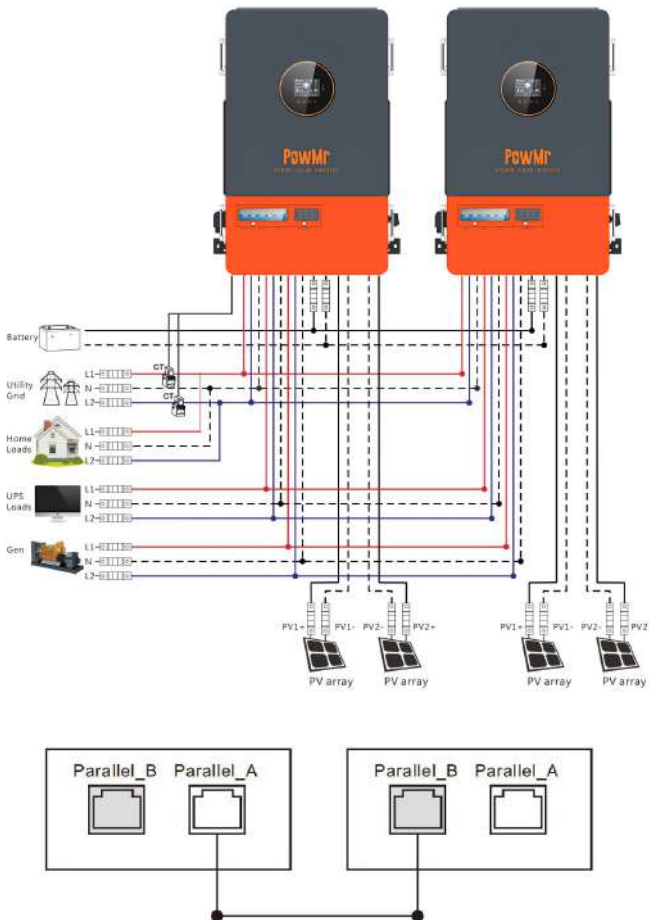

b) Six units connected in parallel:

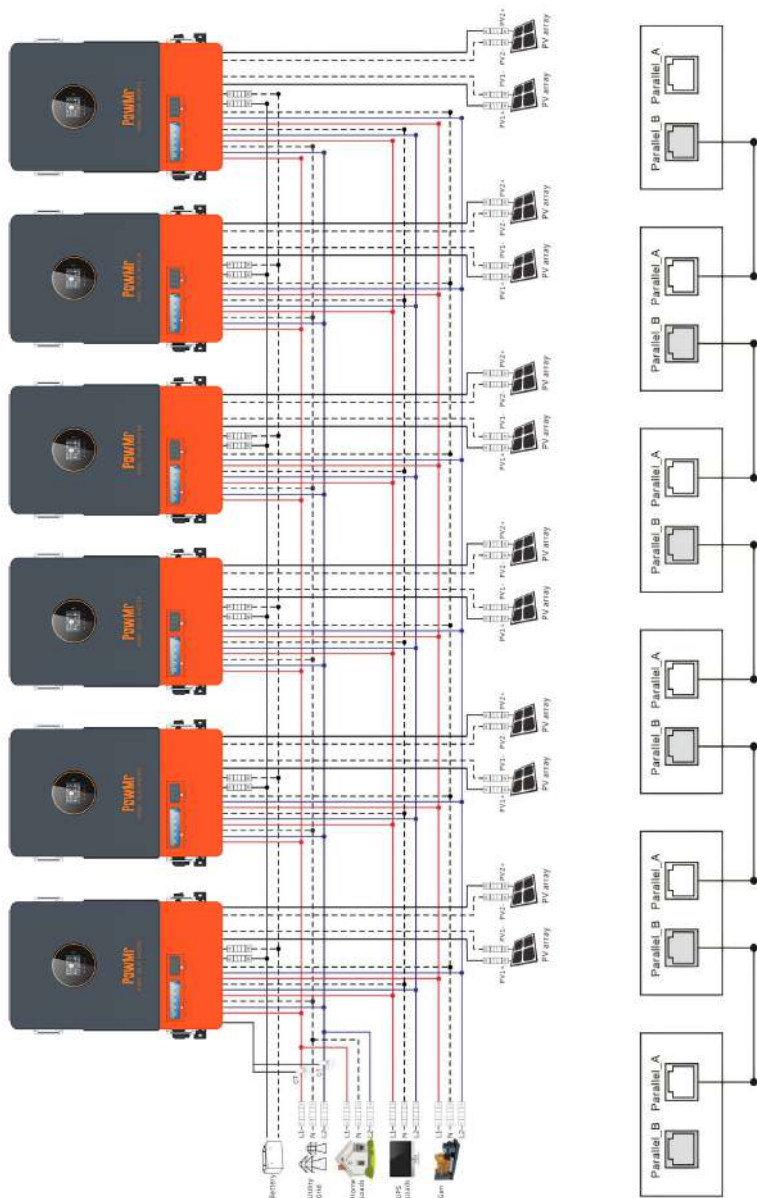

### 10.4 Wiring diagram for three-phase parallel connection

1. Ensure the parallel communication cables of solar energy storage inverters are securely clamped without looseness.
2. When multiple inverters are operating in parallel, refer to the following schematic diagram:

P1: Set the item [31] to "3P1;" P2: Set the item [31] to "3P2;" P3: Set the same to "3P3", all of P1/P2/P3 inverters item [68] can not be set, it is default "120°"; At this point, 3P1-L1 is in phase with 3P3-L2, 3P1-L2 is in phase with 3P2-L1, and 3P2-L2 is in phase with 3P3-L1. The phase difference between the voltages of (3P1-L1, 3P2-L1, 3P3-L1) is 120 degrees. When the output voltage set in [38] is 120Vac, the voltage between the live wire L1 of phase 3P1 and the live wire L2 of phase 3P2 is  $120 \times 1.732 = 208\text{Vac}$ . Similarly, the line voltage between 3P1-L1 and 3P3-L1 is 208Vac, and the line voltage between 3P3-L1 and 3P2-L1 are also 208Vac.

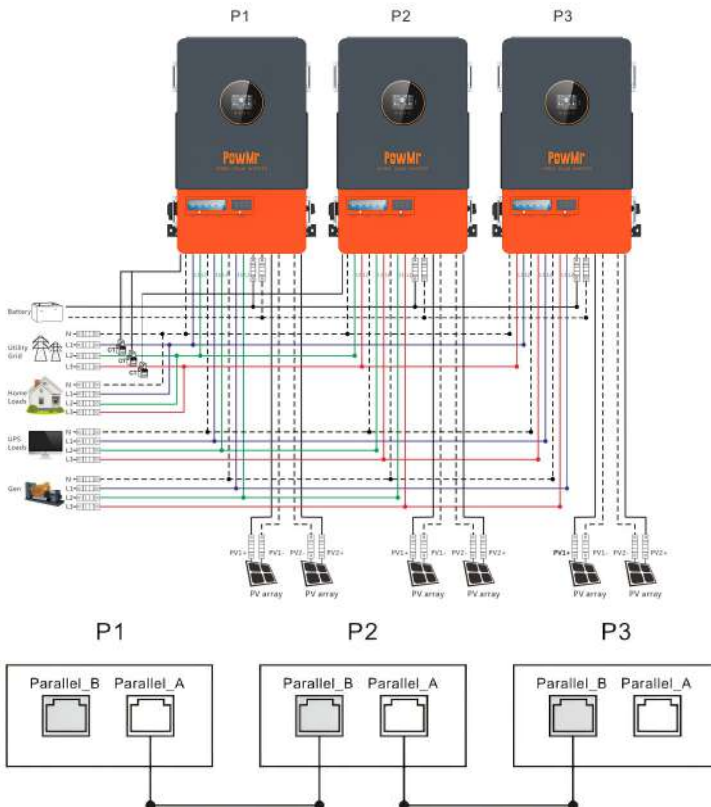

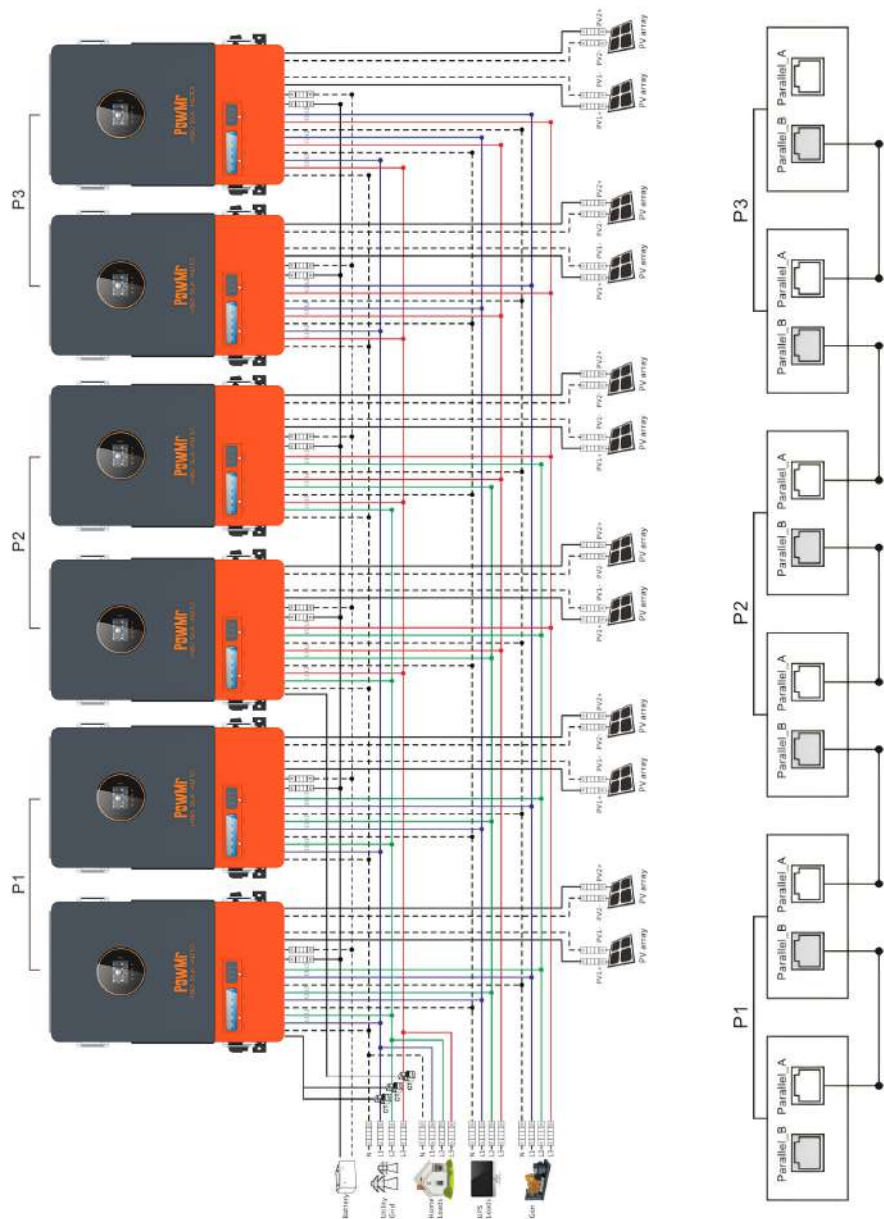

**Notice:**

1. Before powering on and lighting up the screen, check for correct wiring according to the above wiring diagrams to avoid system problems.
2. Check all connections for firm fixing to avoid detachment and abnormal system operation.
3. When connecting the AC output to the load, complete wiring according to the requirements of the electrical load to avoid damage to the load.
4. Setting **【38】** must be configured consistently across all units or set only on the master unit. During parallel operation, the voltage set on the master unit takes precedence, and the master will force all slave units to match this setting. This option is configurable only in standby mode.
5. The machine ships in standalone mode by default. To enable parallel operation or three-phase functionality, configure parameter **【31】** via the display. Procedure: Power on one machine at a time while keeping others powered off. Set parameter **【31】** according to your system's operational mode. After successfully configuring this unit, turn off its power switch and wait for it to power down. Then configure the remaining units sequentially. Once all units are configured, power them all back on simultaneously to enter operational status.
6. In split-phase parallel operation:  
Item **【31】** set to PAL, Item **【68】** set to 180°. When Item **【38】** is set to "120V", the line voltage between L1 and L2 is 240V, while the voltage between L1 and N and between L2 and N is 120V. When setting **【68】** to 120°, and **【38】** to "120V", the line voltage between L1 and L2 is 208V, while the voltages between L1 and N, and L2 and N are 120V.
7. In three-phase parallel operation:  
Set P1 device **【31】** to "3P1", P2 device **【31】** to "3P2", and P3 device **【31】** to '3P3'. The default parameter for **【68】** is "120°" and cannot be modified. At this point, 3P1-L1 and 3P3-L2 are in phase, 3P1-L2 and 3P2-L1 are in phase, and 3P2-L2 and 3P3-L1 are in phase. The voltage phases between (3P1-L1, 3P2-L2, 3P3-L1) differ by 120 degrees. When the output voltage set in **【38】** is 120Vac, the voltage between the live wire L1 of phase 3P1 and the live wire L2 of phase 3P2 is  $120 \times 1.732 = 208\text{Vac}$ . Similarly, the line voltage between 3P1-L1 and 3P3-L1 is 208Vac, and the line voltage between 3P3-L1 and 3P2-L1 are also 208Vac.
8. After the system runs, measure the correct output voltage before connecting to loads.
9. For other unbalanced three-phase parallel inverter systems, please contact the manufacturer for technical support.
10. When operating in parallel, inverters shall be installed in accordance with the proximity principle to avoid communication abnormalities caused by excessively long communication lines. If the line length is unavoidable, additional network cables can be used for end-to-end connection to optimize the communication loop.



# POWMr

SHENZHEN HEHEJIN INDUSTRIAL CO.,LTD

Tel/Fax: +86 755-28219903

Email: [support@powmr.com](mailto:support@powmr.com)

Web: [www.powmr.com](http://www.powmr.com)

Add: Henggang Street, Longgang District, Shenzhen, Guangdong, China